

STEP - BY - STEP  
**STAIRWAY**  
C O N S T R U C T I O N

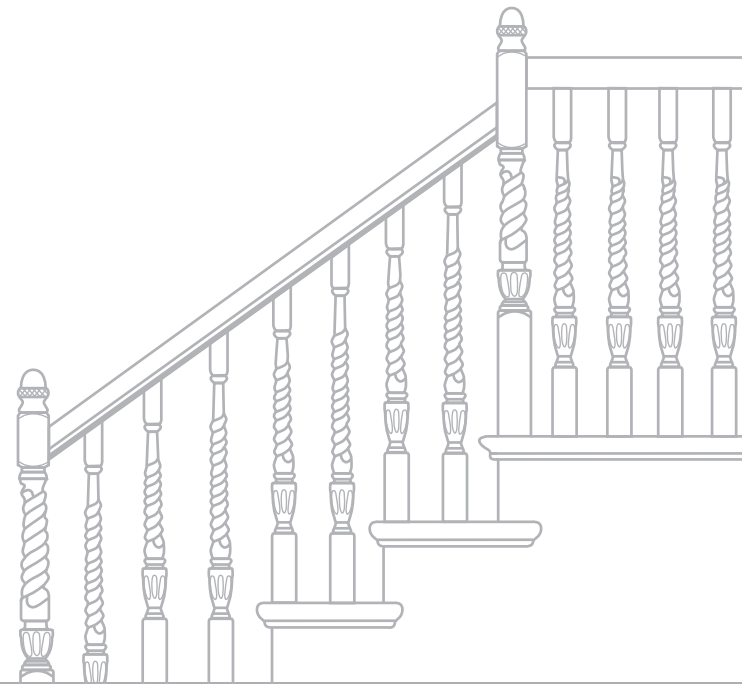

Eighteen easy-to-follow steps for the skilled carpenter

Handy checklist lets you use the Crown Heritage catalog to choose your components

Background information helps you understand the stairway construction process

Over sixty detailed illustrations

STEP - BY - STEP



**STAIRWAY**  
C O N S T R U C T I O N

CROWN HERITAGE  
PO BOX 130, NORTH WILKESBORO, NC 28659  
WWW.CROWNHERITAGE.COM  
800.745.5931

© COPYRIGHT 2005 (CH214/03.25.05/80000)



Visit the Crown Heritage Design Library to download CAD stairpart drawings for your plans.

WWW.CROWNHERITAGE.COM

Crown™  
Heritage

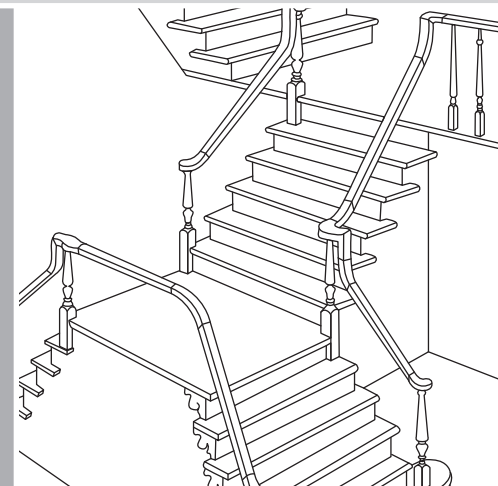

# INTRODUCTION

# INTRODUCTION

## THE CROWN HERITAGE PROMISE

Many skilled amateur handymen, and even experienced professional contractors, are reluctant to tackle stairway construction. And yet, there are few other design elements that can rival a fine hardwood stairway in adding drama and value to the interior of a home. The instructions in this manual have been written in plain language. We invite you to use your basic carpentry skills to follow the nineteen steps in the Crown Heritage system. Regardless of whether your installation is over-the-post or post-to-post, traditional alignment or rail alignment, in the end, you will have a sturdy, beautiful stairway. Take a look at the system outline at the end of the Introduction section and you'll see how our step-by-step approach can put real value into a home.

In this introduction, you will learn some basic facts about Crown Heritage Stair Systems. Before you begin your stairway, familiarize yourself with the nineteen steps in Sections A and B.

In the Introduction section you will:

- Learn how the step-by-step system works.
- Discover why Crown Heritage parts are best for you.
- Learn basic facts about stairways and their construction.

## WHY CROWN HERITAGE?

Crown Heritage Stair System components are the highest quality available anywhere. Turned from solid red oak, the rich wood grain comes alive with the application of stains and varnishes. You may also select components turned from other hardwoods that are suitable for paint finishes. Every Crown Heritage component has been inspected and certified to be free from defects.

Crown Heritage stairways are easy to build. Using this manual and specially designed components exclusive to Crown Heritage, you can build a stairway unmatched in strength and beauty. An intermediate knowledge of carpentry, a knowledge of your local building codes and a set of quality tools are all you will need.

Finally, Crown Heritage System components are easy to buy. The convenient displays and generous inventories make the task of obtaining the parts you need easier than ever before. If you should find any part temporarily out of stock, just place an order with a salesperson and your parts will be shipped through our rapid delivery system to the store for convenient pickup.

## WHAT IS A STAIRNOTE?

StairNotes are some of the many features that make Crown Heritage stairways so easy to build. The steps in Sections A and B give you specific instructions about things you must do to install a stair part.

StairNotes explain the reasoning behind the steps, and provide other helpful information. That's because Crown Heritage thinks it is important for you to fully understand the stairway construction process.

### SECTION CONTENTS:

- i The Crown Heritage Promise
- ii Why Crown Heritage?
- ii What is a StairNote?
- iii Stairway Basics
- iv What's Your Style?
- v Comparison Table
- vi More Important Facts
- vii Contents

# INTRODUCTION

# INTRODUCTION

## STAIRWAY BASICS

A stairway is made up of two basic elements. The first is the rough stair carriage that consists of a series of stringers that provide structural support, and basic elements such as treads and risers for moving people from one level to another. The second element is the balustrade that contributes safety as well as beauty. It is topped off with a handrail system that people may use to support themselves as they go up or down the stairs. The primary structural supports for the balustrade are called newels. Safety and secondary support are provided by balusters (see Fig. i-1).

FIG. i-1 - Stairway Terminology

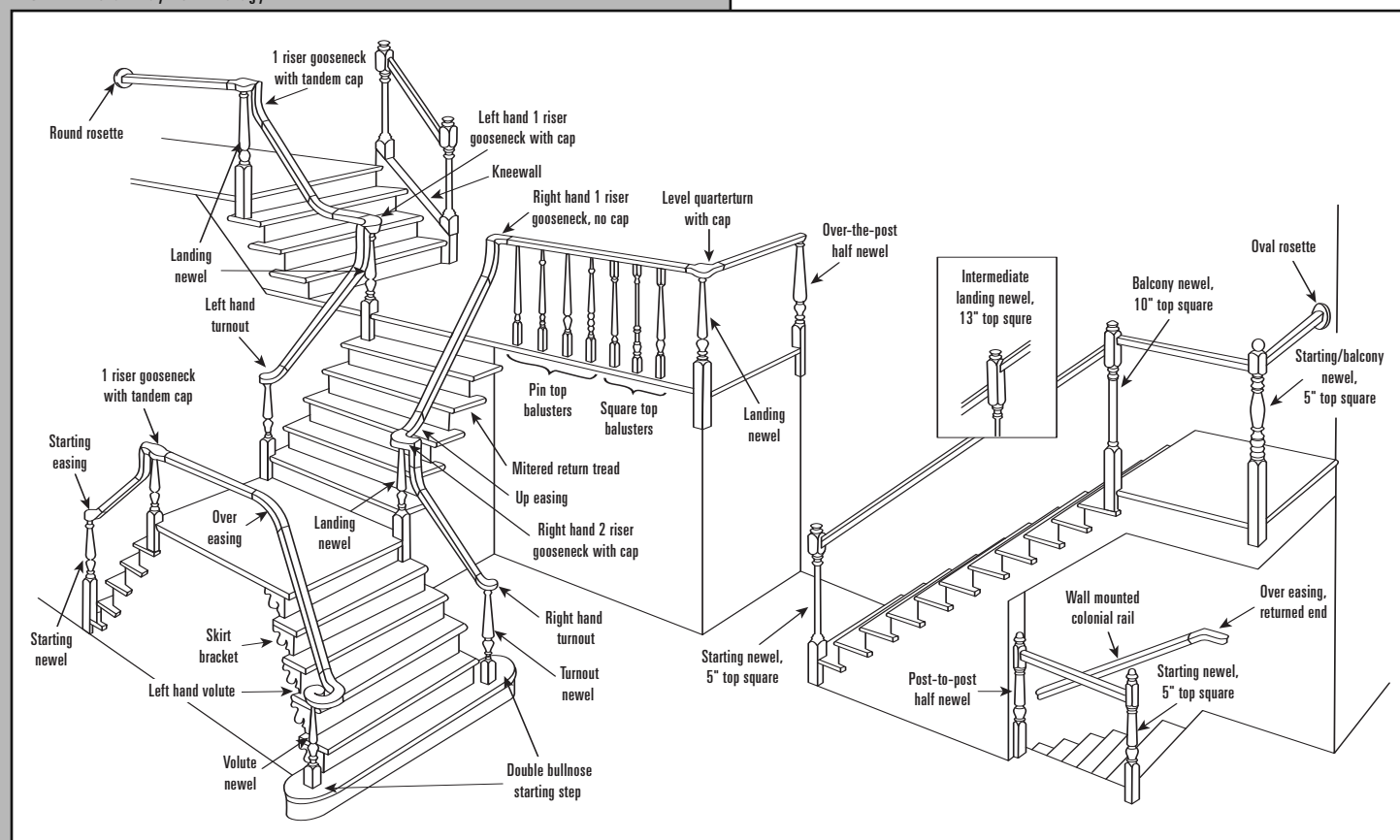

## WHAT'S YOUR STYLE?

The Crown Heritage Stair System includes a wide variety of hardwood and forged iron parts which allow for the construction of two basic stairway designs: post-to-post and over-the-post (see Fig. i-2 and i-3).

In the Crown Heritage catalog, you can familiarize yourself with the various components in a stair system. You will find seven wood and eight forged iron collections of balusters and newels to choose from. Four of these collections are suitable for either post-to-post or over-the-post installations ("Williamsburg," "1800's," "Carolina" and "Colonial"). Hampton and Classic are two very popular collections that are only available for post-to-post installations.

Crown Heritage also offers the choice between "traditional" and "rail oriented" baluster systems. Most historic (traditional) balustrades have bottom features such as bottom blocks and turnings that align parallel with the treads, and top features such as rings, top blocks and top of flutes that align parallel with the handrail. Using the patented "Crown System" balusters, perfect alignment of the baluster top features can be achieved, regardless of whether the installation has two or three balusters per step. Other stair part manufacturers cannot offer this alignment. "Rail oriented" balusters are turned so that all features, both top and bottom, align with the handrail as long as all balusters are trimmed to length from the bottom.

FIG. i-2 - Typical over-the-post stairway

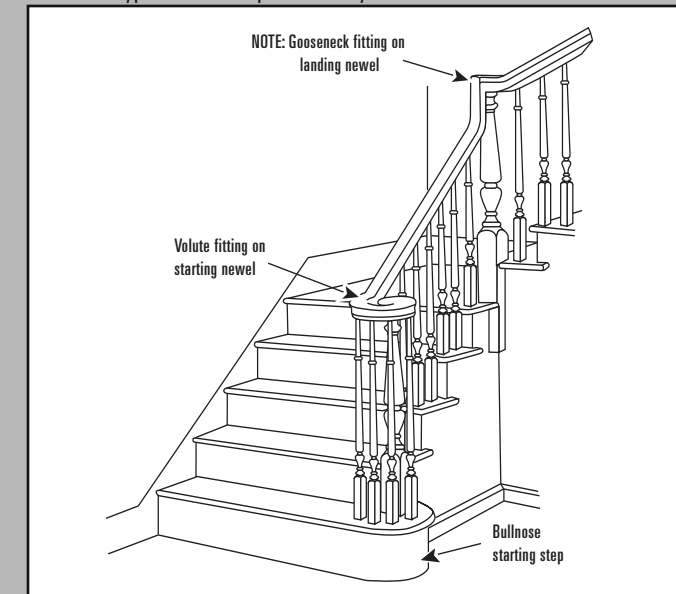
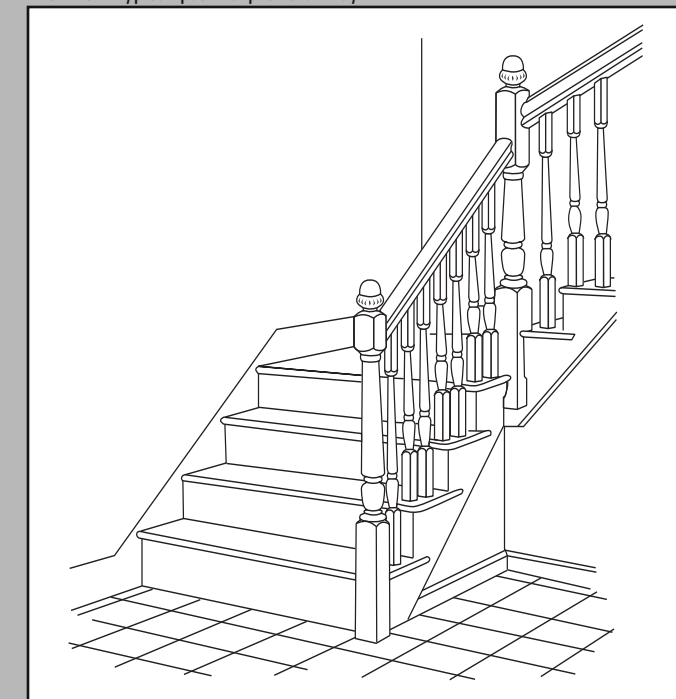

FIG. i-3 - Typical post-to-post stairway



# INTRODUCTION

# INTRODUCTION

## COMPARISON TABLE

	Williamsburg	1800's	Jefferson	Carolina	Colonial	Hampton	Classic
Suitable for Over-the-Post	X	X	X	X	X	X	
Suitable for Post-to-Post	X	X	X	X	X	X	X
Square top balusters available*	X	X		X	X	X	X
Pin top balusters available	X	X	X	X	X	X	

\*Requires plowed rail.

Best Handrail Selection:

	Williamsburg	1800's	Jefferson	Carolina	Colonial	Hampton	Classic
6010					X		
6210	X	X	X	X	X	X	
6310	X	X	X	X		X	
6519	X	X	X	X		X	
6203							X
6100	X	X	X	X	X	X	X

The Crown Heritage handrail comes in several styles and is available either “plowed” to accept square-top balusters or “unplowed” for pin-top balusters. Refer to the table on page v for suggestions on matching handrail with your favorite Crown Heritage collection.

Fittings (see Fig. i-4) are handrail parts used mainly, but not exclusively, in over-the-post installations. Fittings like the volute shown at the base of the handrail in Fig. i-2 add an extra element of drama and beauty to the handrail. Easings and goosenecks make it possible to fit the handrail to the geometry of almost any stairway.

Starting steps (see Fig. i-5) are either of the “bullnose” type (as shown in Fig. i-2), or the “quarter circle” type. Consult *StairNote Five: All About Starting Steps* for additional background information on starting steps.

The Crown Heritage System also features the specialized hardware needed for building a sturdy stairway. Suggestions for use of the hardware are found throughout this manual.

## MORE IMPORTANT FACTS

FIG. i-4 - Handrail fittings

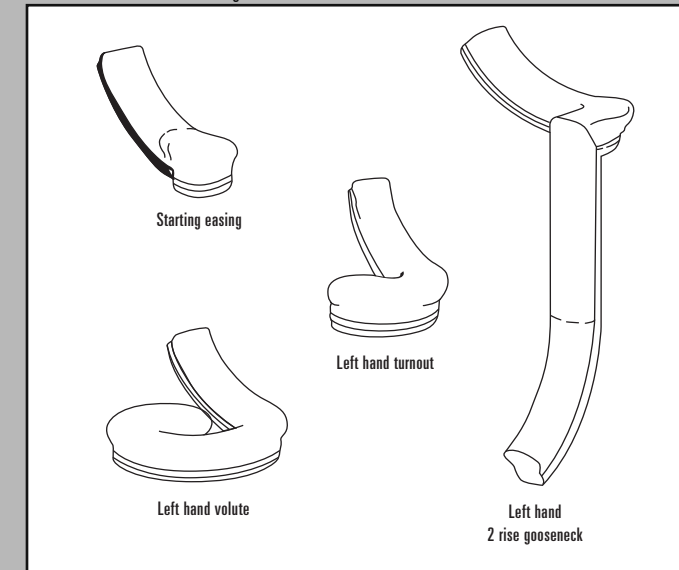
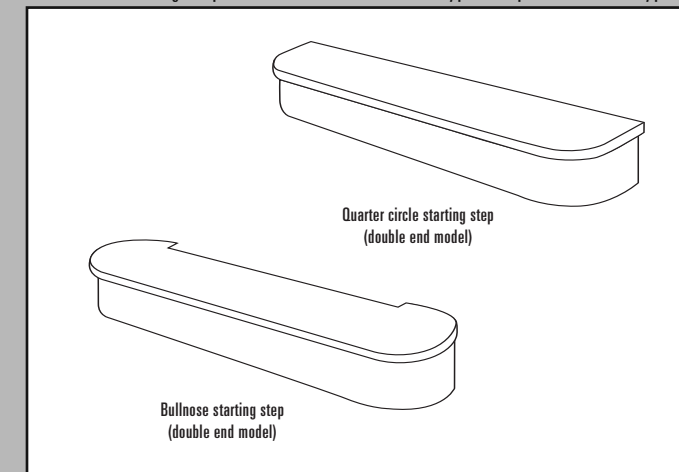

FIG. i-5 - Starting steps can be either “bullnose” type or “quarter circle” type



## CONTENTS

## CONTENTS

**SECTION A:**

Layout and Construction of the Rough Stair Carriage

Follow the seven steps in this section if you intend to design and build a stairway from scratch. If you are constructing a balustrade on an existing stairway or remodeling, review Section A, then go directly to Section B.

- 1 . . . STEP A.1    Cut the Stringers
- 3 . . . STEP A.2    Install the Stringers
- 4 . . . STEP A.3    Brace and Block the Stringers
- 5 . . . STEP A.4    Install Skirt Board
- 6 . . . STEP A.5    Install the Risers
- 8 . . . STEP A.6    Dry Fit the Starting Step
- 9 . . . STEP A.7    Dry Fit the Stair Treads

**SECTION B:**

Layout and Construction of the Balustrade

Follow the twelve steps in this section to add the balustrade, the newels, balusters and handrail to your stairway.

- 10 . . STEP B.1    Lay Out the Balustrade
- 10 . . . . . B.1a    Find the Baluster Line and Mark  
Baluster Positions
- 13 . . . . . B.1b    Mark the Newel Positions
- 14 . . STEP B.2    All About Newels
- 14 . . STEP B.2a    Post-to-Post Newels
- 17 . . STEP B.2b    Over-the-Post Newels
- 20 . . STEP B.3    Install the Starting Newel
- 20 . . . . . B.3a    Installing a Starting Newel in an Over-the-  
Post Stairway With a Bullnose Starting Step
- 23 . . . . . B.3b    Installing a Starting Newel in Over-the-  
Post or Post-to-Post Stairways with Plain  
Tread or Mitered Tread
- 25 . . STEP B.4    Install the Starting Step
- 26 . . STEP B.5    Install the Remaining Treads
- 27 . . STEP B.6    Install the Landing Newel(s)
- 28 . . STEP B.7    Install the Balcony Newel(s)
- 29 . . STEP B.8    Install the Half-Newel or Rosette
- 30 . . STEP B.9    Assemble and Dry Fit the Handrail
- 30 . . . . . B.9a    Over-the-Post Handrail
- 34 . . . . . B.9b    Post-to-Post Handrail
- 35 . . STEP B.10    Install the Balusters
- 37 . . . . . B.10a    Installing Pin Top Balusters
- 38 . . . . . B.10b    Installing Square Top Balusters
- 39 . . . . . B.10c    Installing Forged Iron
- 43 . . STEP B.11    Complete the Balustrade Assembly
- 44 . . . . . B.11a    Stairways with Pin Top Balusters
- 45 . . . . . B.11b    Stairways with Square Top Balusters
- 46 . . STEP B.12    Stains, Varnishes and Paints: Finishing  
Your Balustrade

**APPENDICES**

- 47 . . Bending Rail Installation
- 50 . . Troubleshooting Reference
- 53 . . Hardware Installation Instructions
- 56 . . The Promenade Series
- 60 . . 4" Sphere Rule Table

## STAIRNOTES

- 1 . . . . . *One: Planning for Headroom and Width*
- 2 . . . . . *Two: How to Calculate "Rise" and "Run"*
- 3 . . . . . *Three: How to Make a Pitch Block*
- 5 . . . . . *Four: Why Use Skirt Boards?*
- 7 . . . . . *Five: All About Starting Steps*

## STAIRNOTES

- 22 . . . . . *Six: Starting Newels and Handrail Height*
- 23 . . . . . *Seven: The Williamsburg Collection*
- 24 . . . . . *Eight: How to Notch a Newel*
- 25 . . . . . *Nine: Squeakless Stairways*
- 36 . . . . . *Ten: All About Balusters*
- 43 . . . . . *Eleven: The Classic Collection:  
Breaking All the Rules*

# SECTION A SECTION A

## STEP A.1

FIG. 1-1 - Laying out treads and risers on a 2 x 12 stringer

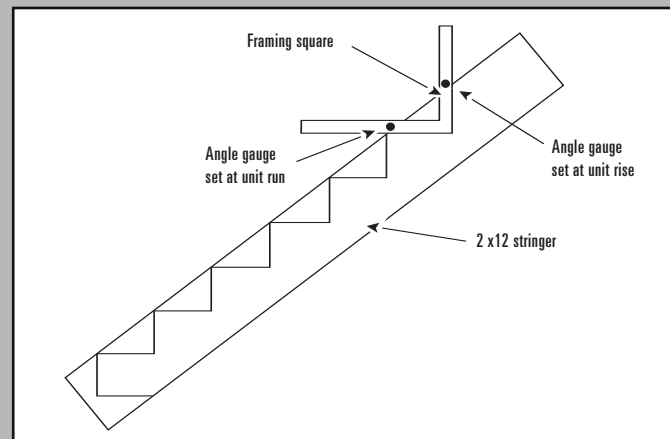

## STAIRNOTE ONE PLANNING FOR HEADROOM AND WIDTH

FIG. S-1a - Stairway headroom

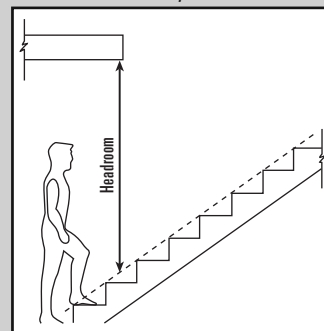

Headroom is the distance measured vertically from the sloped plane adjoining the tread nosing or from the floor surface of the landing or platform to the underside of any overhead obstruction. Most staircases are comfortable to use if they have headroom of 7'4" or more. Headroom should never be less than 6'8".

Stairway width is defined as the Minimum inside clearance width from handrail to handrail or handrail to wall.

The width of your stairway must allow room for two people to pass on the stairs, and for bulky furniture to be carried up and down. We recommend at least 42".

FIG. S-1b - Stairway width

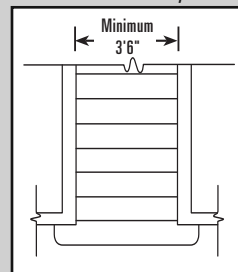

A solid and durable stairway depends on its support system. In this section, you will learn how to plan and build the load-bearing structure that will become the means for moving people and objects from one level of your building to the next. Consult a qualified professional for load-bearing requirements.

Accurate and correct construction of the rough stair carriage will make it much easier for you to install the balustrade (Section B).

### STEP A.1 - Cut The Stringers

See *StairNote One: Planning for Headroom and Stairway Width*

See *StairNote Two: How to Calculate "Rise" and "Run"*

After referring to *StairNote Two: How to Calculate "Rise" and "Run,"* use a framing square, lay out the correct number of risers and treads on a 2 x 12 (see Fig. 1-1). Remember that in any stairway, the number of treads is always one less than the number of risers since a stairway always begins and ends with a riser.

Keep in mind also that the nosing on the treads will project about 1" from the riser and must be kept from interfering with a door or with passage in a hallway.

The first riser must be cut shorter than the others by the thickness of the tread (1/32"). Note this will automatically increase the topmost riser by the same amount, but this will be made up when the treads are installed.

Cut at least one stringer for each 12 to 18 inches of stairway width.

See *StairNote Three: How to Make a Pitch Block*

A stairway is a structure designed to aid people in moving safely from one level to another. You must begin your design by measuring the total horizontal distance they will travel on the stairway, OVERALL RUN, and the total vertical distance, (from finished floor to finished floor), OVERALL RISE. Study Fig. S-2a to familiarize yourself with this concept.

FIG. S-2a - Overall rise and run

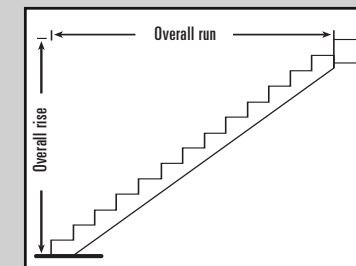

For the sake of comfort and safety, you must now divide the overall rise and overall run into smaller units that we will call simply RISE and RUN (see Fig. S-2b).

FIG. S-2b - Rise and run, fundamental stairway construction concepts

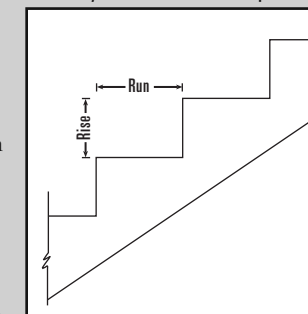

The optimum rise is 7 1/2", with 8" as a maximum. Optimum run is 10" or more.

**RULE OF THUMB:** The sum of run and rise should equal between 17" and 18". (Example: 7 1/2" rise + 10 1/4" run = 17 3/4".) **Be familiar with your local building code requirements on this point.**

Now begin by dividing the overall rise by the optimum rise of 7 1/2".

EXAMPLE:  $105" \div 7\frac{1}{2}" = 14$

Thus your stairway would require 14 risers of 7 1/2" each to move someone a vertical distance of 105" (8'9"). It will seldom happen that your risers will work out to exactly 7 1/2". The necessary rise height is determined by dividing the overall rise by the whole number nearest the number of risers for the optimum rise.

EXAMPLE:  $106\frac{3}{4}" \text{ overall rise} \div 7\frac{1}{2}" \text{ optimum rise} = 14.23$   
 then  $106\frac{3}{4}" \text{ overall rise} \div 14 \text{ (14.23 rounded down)} = 7\frac{5}{8}" \text{ necessary rise height.}$

## STAIRNOTE

### HOW TO CALCULATE

# TWO

## "RISE" AND "RUN"

Since all stairways start and end with a riser, there will always be one less tread than the number of risers. Thus, on the 14-riser stairway we have begun planning above, there will be 13 treads. For an overall run of 133 1/4", the run will be 10 1/4".

EXAMPLE:  $133\frac{1}{4}" \text{ overall run} \div 13 \text{ steps} = 10\frac{1}{4}" \text{ run}$

FIG. S-2c - Cutaway view of typical tread/riser installation

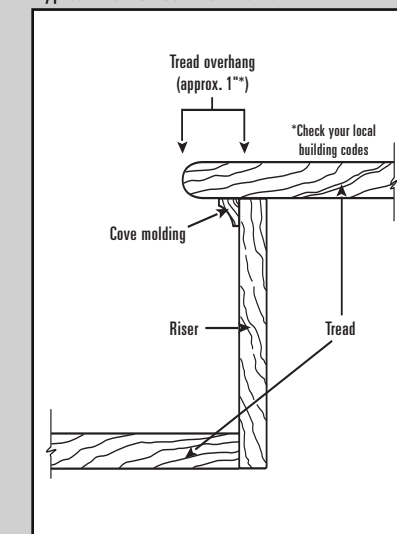

If you have the space, you may adjust the overall run to make the run come out even. Be careful not to let it run too far, or your stairway may interfere with a door or obstruct a hallway.

Remember that the treads will be approximately 1" deeper than the run (see Fig. S-2c). Thus, a 10 1/4" run will call for an 11 1/4" tread, (about 1/2" for cove moulding and about 1/2" for tread overhang).

## SECTION A SECTION A

STEP  
A.2

FIG. 2-1 - Cleats, ledgers and reinforced mounting points are required for sturdy installation

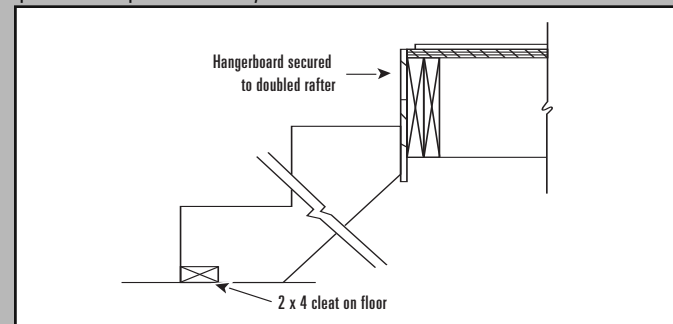

## STEP A.2 - Install The Stringers

Sturdiness and safety demand secure mounting of the stringers. Use of a cleat at the lower end and a plywood hangerboard at the upper end (see Fig. 2-1) are the best guarantee of this. Also, plan to install vertical support framing at one or more points, consistent with future use of the area under the stairway. If you plan to add sheetrock and/or skirt boards, place a spacer of equal or greater thickness between the stringer and any adjacent roughed-in walls.

## STEP A.3 - Brace and Block the Stringers

An important consideration for a sturdy installation is to install sufficient bracing at key points in the rough carriage. Points at which newel posts will be mounted, where rails will terminate or where outside skirt boards and decorative trim will be applied should all be carefully framed and reinforced at this stage (see Fig. 3-1).

STEP  
A.3

FIG. 3-1 - Bracing and blocking the rough stair carriage

STAIRNOTE  
THREE  
HOW TO  
MAKE A PITCH BLOCK

FIG. S-3a - Save a triangle of wood from your stringer. Mark it as shown. It will become your pitch block.



The pitch block is a right triangle cut from 2 x 12 lumber that will become a critical measuring tool for constructing the balustrade. Save one of the triangles cut from a stringer. (Remember that critical measurement and cutting of stringers is a basic necessity for a good stairway. Accuracy to within  $\frac{1}{32}$ " will make the installation go smoother.)

The pitch block reproduces the exact angles of the stairway. Mark its three sides as shown in Fig. S-3a, and put it aside for later use.

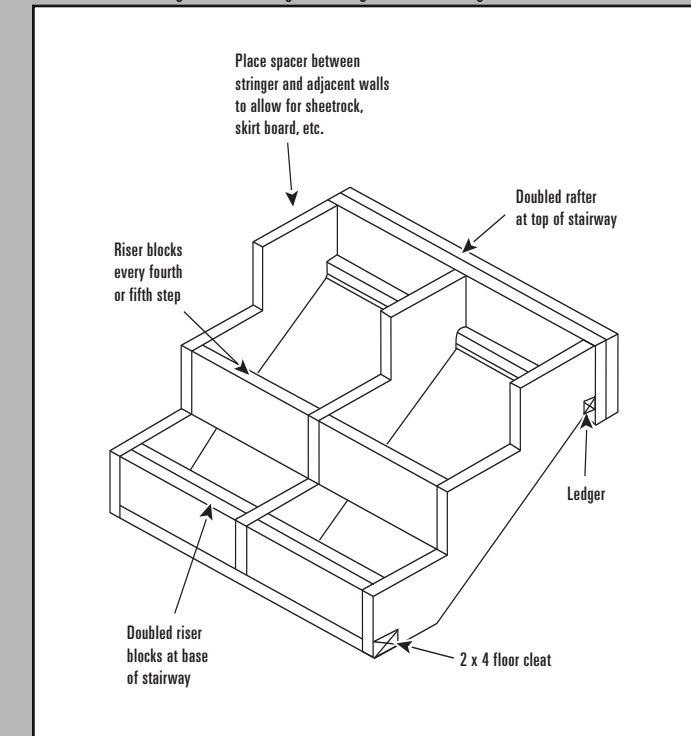
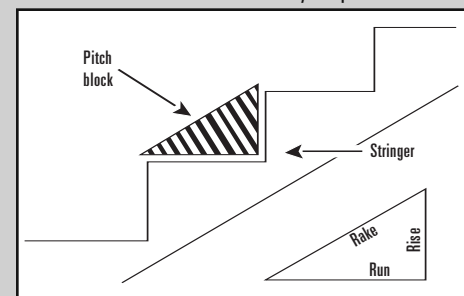
## ALTERNATE METHOD:

If no triangle cut from a stringer is available, lay a straightedge across the tread nosings and use it to mark a piece of plywood as shown in Fig. S-3b. Make sure the plywood is square and that it is held firmly against the tread nosing.

FIG. S-3b - Making a pitch block for an existing stairway

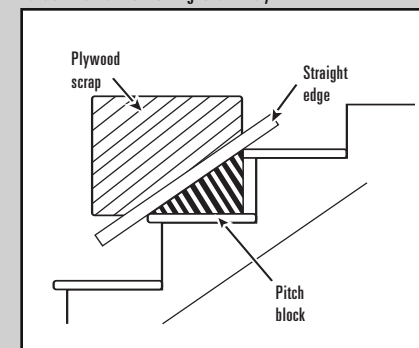

*NOTE: The rise and run should remain the same throughout the stairway; however, IF THE RISE AND RUN VARIES FROM FLIGHT TO FLIGHT, make a separate pitch block for each flight of stairs.*

## SECTION A SECTION A

STEP  
A.4

FIG. 4-1 - Skirt board can enhance a stairway

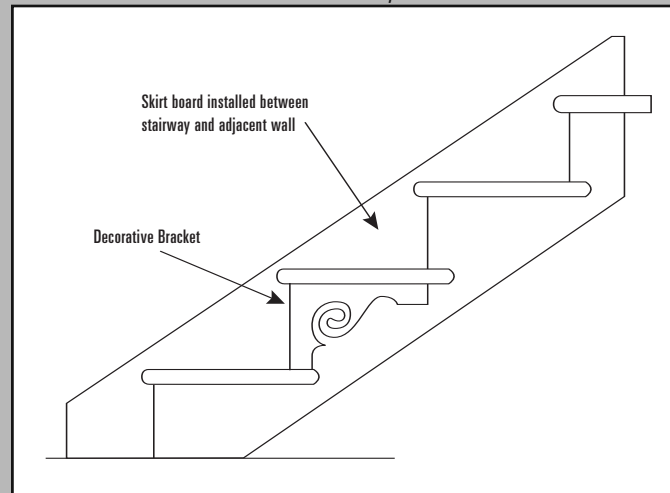

## STEP A.4 - Install Skirt Board

See *StairNote Four: Why Use Skirt Boards?*

Install skirt boards (optional) wherever the stair treads will butt against a wall (see Fig. 4-1). Outside skirt boards are installed after the open wall is finished with sheetrock or other finishing material. If outside skirt boards are specified, miter the riser ends and the riser cut on the skirt board at a 45° angle to avoid the need for skirt brackets (see Fig. 4-2).

*NOTE: Mitering a skirtboard is considered advanced carpentry. Another option is to cut them to the same pattern as the stringers, using a square cut. This will leave the ends of the risers exposed, to be covered at a later stage with a skirt bracket.*

## STEP A.5 - Install the Risers

Risers need to be trimmed to the proper height and length. Measure the rise of all steps to ensure consistency. Rip the risers  $\frac{1}{16}$ " less than the smallest rise. Each riser must be cut to length individually. For a stairway that is open on one side, place the riser across the stringers and butt up to the wall skirt board. Scribe a line on this end, transferring the actual contour of the skirt board to the end of the riser. Trim to this line. Butt the riser back to the wall skirt board, allowing the other end to project out past the mitered skirt board. Make a mark on the front side at the bottom of the riser where it intersects the outside of the mitered skirt board. Make a mark on the back side at the top of the riser where it intersects the skirt board and transfer this mark to the front side using a tri-square. Draw a line connecting these two marks and cut on this mark at a 45° miter. Use carpenter's glue on the miter and apply construction adhesive on the stringers before nailing securely. Follow this procedure on each riser.

For a stairway that is open on both sides, follow the same procedure as described above to rip the risers. Marking the length is a matter of placing the riser across the stringers so that each end of the riser projects past the long point of the skirt board miter. Make a mark on the front side at the bottom of the riser where it intersects the outside of the mitered skirt board. Make a mark on the back side at the top of the riser where it intersects the skirt board and transfer this mark to the front side using a tri-square. Draw a line connecting these two marks and cut on this mark at a 45° miter. Use carpenter's glue on the miter and apply construction adhesive on the stringers before nailing securely. Follow this procedure on each riser.

STEP  
A.5

FIG. 4-2 - Skirt board and risers may be mitered to conceal exposed ends

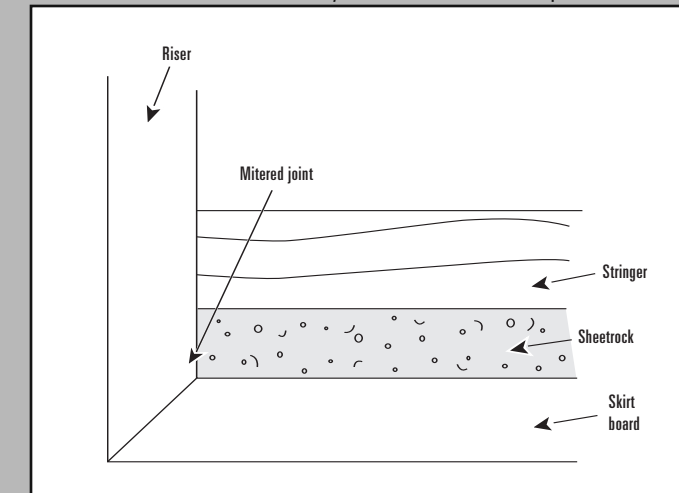

## STAIRNOTE

## FOUR

WHY USE  
SKIRTBOARDS?

FIG. S-4 - Skirt board against stairway wall and against open wall with overlay of decorative skirt brackets

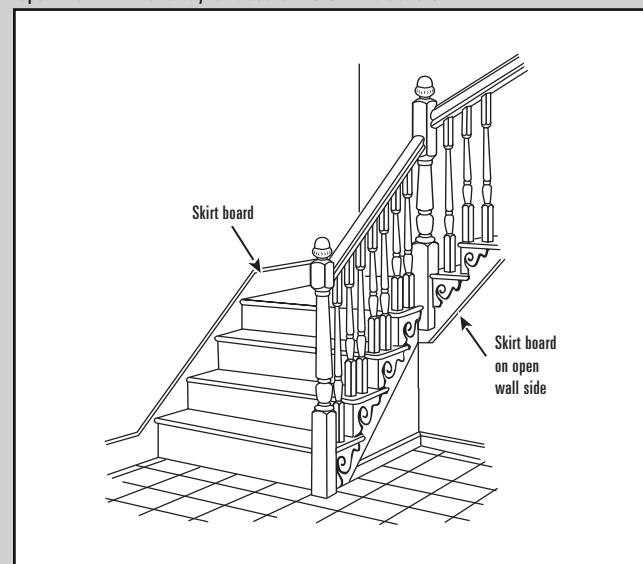

Skirt board is an optional design feature that can enhance a stairway in two ways: First, when used against a wall, especially a sheetrock board or other soft porous surface, a skirt board lowers maintenance by providing a scuff-and impact-resistant surface at the tread level. Second, skirt board presents a design opportunity by continuing the baseboard theme along one or both sides of the stairway, and providing an opportunity to border the stairway with either woodgrain or painted (to complement the risers) vertical surfaces for a more finished look (See Fig. S-4).

## SECTION A

## SECTION A

STEP  
A.5

If the stairway is closed on both sides, the task of scribing both ends must be done on scraps and transferred to the actual risers. Rip all risers and scraps as described above. Cut all scraps  $\frac{1}{2}$ " shorter than the smallest inside dimension. Place a scrap riser across the stringers, butt one end against the skirt board, and scribe a line. Now do the same at the other end. Trim both ends to the scribe lines. Now place the scrap back on the stringers and butt either end tightly to the skirt board. Precisely measure the distance from the other end of the riser to the skirt board. Lay the scrap on the actual riser blank and transfer one scribe line to the riser. Slide the scrap toward the other end the exact distance that was measured above. Scribe and trim the other end. Use a  $3^\circ$  bevel to make this cut and it will be easier to swing this end into place.

## STEP A.6 - Dry Fit the Starting Step

See Step B.2 and StairNote Five: All About Starting Steps

NOTE: If no starting step is to be used (first tread same as all others), go to Step A.7.

Begin by dry fitting the starting step riser (leave the tread off). Rip it to the height of the first riser on the stringers. Always rip the bottom edge of the riser. A table saw will provide the smoothest and easiest cut. Slide the starting step riser along the saw blade and carefully roll the riser up to complete the trimming on the bullnose end (see Fig. 6-1). Any irregularities in the cut will be hidden later by the finish flooring or by shoe molding.

Determine the dimension of the first rise and rip the starting riser  $\frac{1}{16}$ " less. Place the riser end against the wall skirt board and measure the gap between the curved end and the mitered skirt board. Subtract  $\frac{1}{2}$ " from this dimension and trim that much off the straight end. Slide the riser back in place, but put a  $\frac{3}{4}$ " piece of scrap between the curved end and the skirt board. Scribe a line on the straight end, using a  $\frac{3}{4}$ " block (see Fig. 6-2). Trim to this scribe line and check for a snug fit.

The tread is cut to length in a similar manner. Place the tread on the riser and butt the straight end against the wall skirt board. Measure the gap between the notch and the mitered skirt board on the curved end. Subtract  $\frac{1}{2}$ " from this dimension and trim that much off the straight end. Slide the tread back in place, but put a  $\frac{3}{4}$ " piece of scrap between the notch and the mitered skirt board. Scribe a line on the straight end, using a  $\frac{3}{4}$ " block. Trim and check for a snug fit.

STEP  
A.6

FIG. 6-1 - Cutting a starting step riser

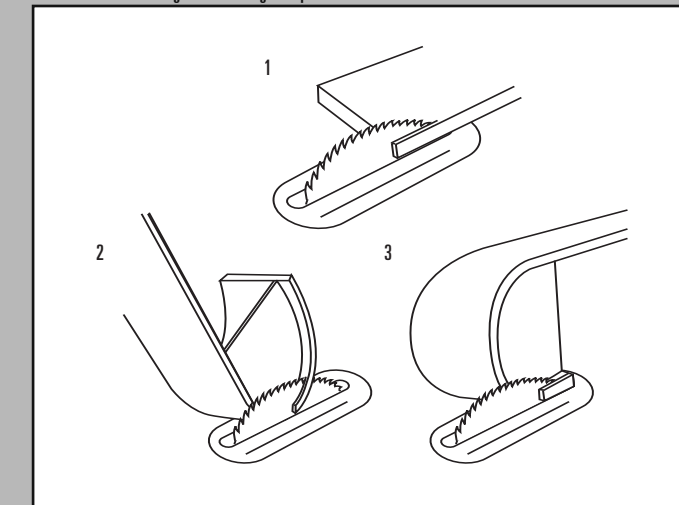
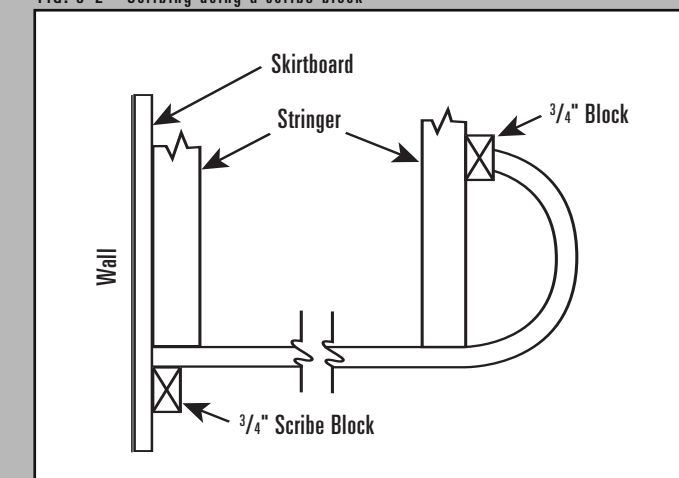

FIG. 6-2 - Scribing using a scribe block



## STAIRNOTE

## FIVE

ALL ABOUT  
STARTING STEPS

FIG. S-5a - Starting steps add character and distinction

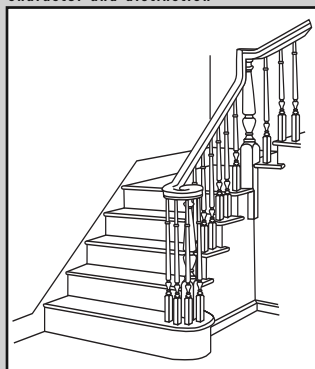

Starting steps add character and distinction to a stairway. The gently rounded riser of a starting step relieves the "boxy" look of a plain stairway. In over-the-post installations the projecting "bullnose" ends permit the placement of newels off the centerline. This allows the use of a handrail that starts with a decorative curved volute or turnout.

first newel is usually at the second riser. Verify this installation will comply with local building code. Additionally, quarter circle starting steps work well with post-to-post installations (see Fig. S-5b).

FIG. S-5b - Quarter circle starting steps also can be used in post-to-post installations

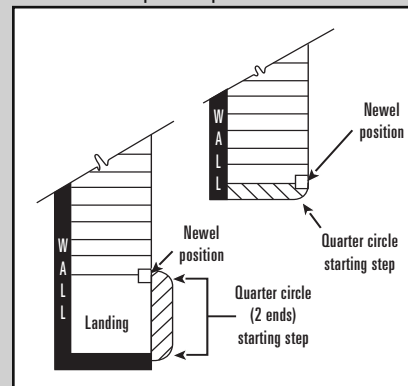

Study the selection of starting steps, treads, and risers in the catalog for a better understanding of this beautiful feature of the Crown Heritage Stairway System.

Bullnose starting steps increase the overall width of a staircase by approximately 10" to 11 $\frac{1}{4}$ ". An exception to this is the "quarter circle" design that is intended for use in installations where the

## SECTION A

## SECTION B

STEP  
A.7

FIG. 6-3 - Cutaway view of the bullnose end of a starting step

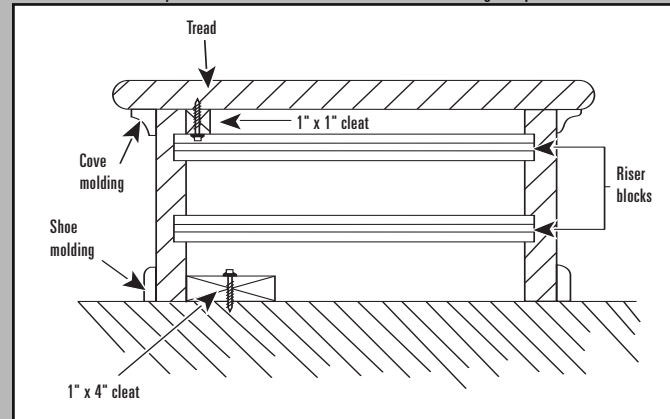

(Step A.6 cont.)

Remove the entire assembly and attach the 1" x 4" cleat to the floor (see Fig. 6-3). Attach smaller cleats (approximately 1/4" x 1/4" stock) to the inside top edge of the riser. Space these small cleats so they will fall between the stringers.

For final installation *after installing the newels* (see Step B.3), turn the starting step (tread and riser) upside down and assemble it with carpenter's glue or construction adhesive on all surfaces and screws through the cleats. Be careful not to scratch the tread.

**WARNING: Until newels are ready to be installed, do not permanently glue the starting step.**

## STEP A.7 - Dry Fit the Stair Treads

Rip treads to allow 1"-1/8" overhang (check local codes). On a miter returned tread, this may involve remitering the return or finishing the rip with a hand saw.

For a stairway open on one side, follow the same steps as described for trimming the starting step to length, i.e., scribe, trim, butt, measure, rescribe and trim.

Treads installed between two walls would be trimmed in the same manner as described in the riser section (Step A.6).

The stair carriage is now complete and ready for installation of the balustrade. Braced and blocked stringers are in place; riser and skirt board are permanently mounted. The treads and starting step are just dry fitted to allow installation of starting newel and for notching of treads as other newels are installed. Go to Section B to construct the balustrade.

STEP  
B.1a

## STEP B.1 - Lay Out the Balustrade

## B.1a - Find the Baluster Line and Mark Baluster Positions

The baluster line defines the centerline of the entire balustrade. Newels, balusters and handrail will eventually be centered on it.

Traditionally, the balustrade centerline should allow the outside face of the baluster to line up in the same plane as the finished surface below the tread, i.e. sheetrock or skirtboard. Therefore the centerline location (measured from the outside edge of the tread return) should be equal to 1/2 the thickness of the baluster plus the overhang dimension (as determined in Step A.7, see Fig. 8-1 & 8-2).

Said another way, the baluster line represents the centerline of a row of balusters whose outside faces line up with the finished wall, or skirt board, below the tread. Mark the baluster line on the first tread, and each succeeding tread in the flight.

**NOTE: If the handrail is to terminate against the end of a wall, the baluster line should be centered on the wall to allow for symmetrical mounting of a rosette or half newel (see Fig. 8-3). Remember to maintain appropriate stairway width for compliance with local building code requirements.**

FIG. 8-1 - Baluster line location

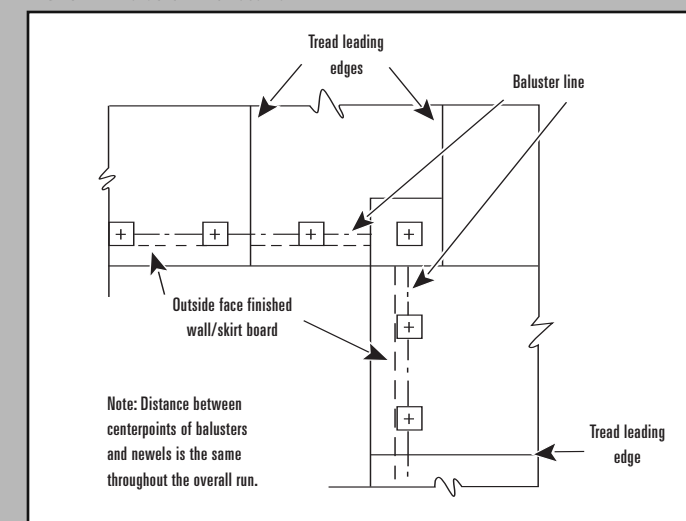
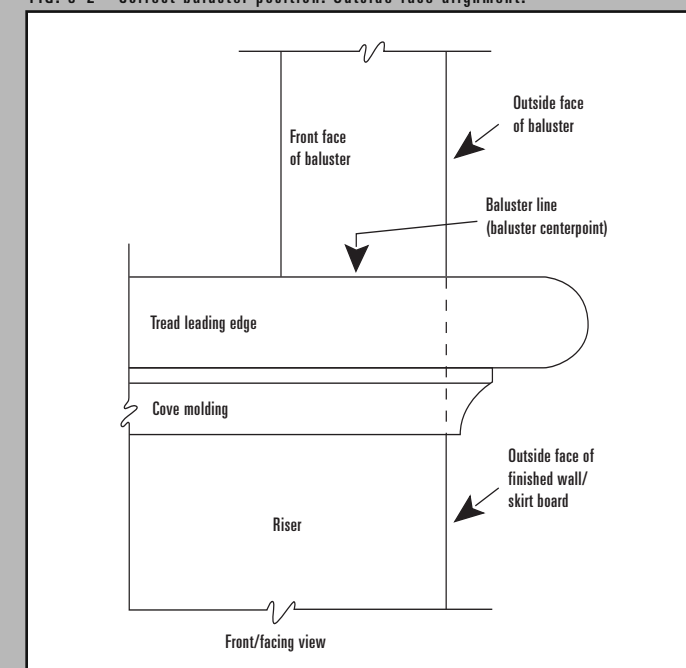

FIG. 8-2 - Correct baluster position. Outside face alignment.



# SECTION B

# SECTION B

## STEP B.1a

FIG. 8-3 - Adjusting baluster centerline for termination into a wall

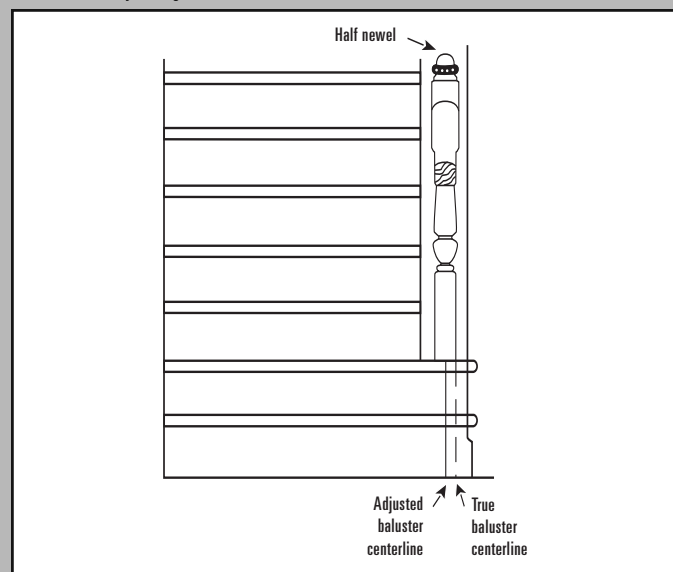
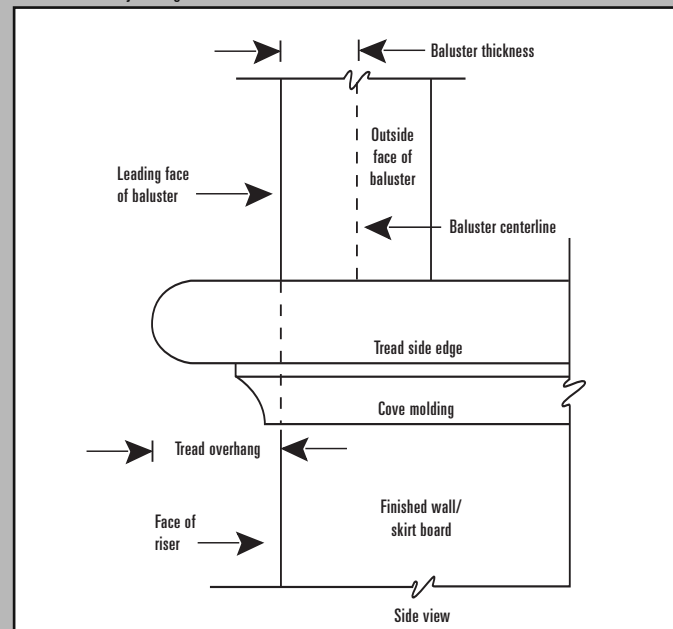

FIG. 8-4 - Adjusting baluster centerline for termination into a wall



Now find the location of the first baluster on the tread. It will be on the baluster line, and the leading face of the baluster should be in line with the face of the riser beneath the tread (see Fig. 8-4).

The mathematical formula is:

$$\frac{\text{baluster square thickness}}{2} + \text{tread overhang} = \text{distance from front edge of tread to center of first baluster (see Fig. 8-5)}$$

**WARNING:** If the first baluster is not correctly positioned, it may not be long enough to properly penetrate the rail.

Remembering that your objective is to space balusters evenly throughout the balustrade, find the locations of the second and/or third balusters on the tread using the following formula:

$$\frac{\text{run}}{\text{no. of balusters}} = \text{distance between centerpoints of balusters (and newels) throughout the overall run (see Fig. 8-6)}$$

Example: (Using the figures from Fig. 8-6)  
If you are placing three balusters per tread and the run is 10 1/2", the distance between centerpoints will be  $\frac{10\frac{1}{2}''}{3} = 3\frac{1}{2}''$

**NOTE:** All baluster and newel centerpoints will be located at this interval on the baluster line, throughout the entire balustrade. (Even though newel diameters are larger, the newel centerpoint should be located exactly where the baluster centerpoint would be.) Placement on each tread is measured from the first baluster centerpoint, as determined above.

**WARNING:** Building codes are increasingly requiring adherence to something called the "Four-Inch Sphere Rule." Currently, the IRC 2003 code in most states requires baluster spacing on open treads that does not permit pass-through of a 4 3/8" sphere. Baluster profile and spacing are the two variables which determine your compliance. You may be required to use three balusters per tread to comply with this rule. As always, be aware of local building codes. Refer to Appendix 5 (page 58) for more information.

Now, mark the centerpoints of all the balusters on the baluster line.

## STEP B.1a

FIG. 8-5 - First baluster position: mathematical method

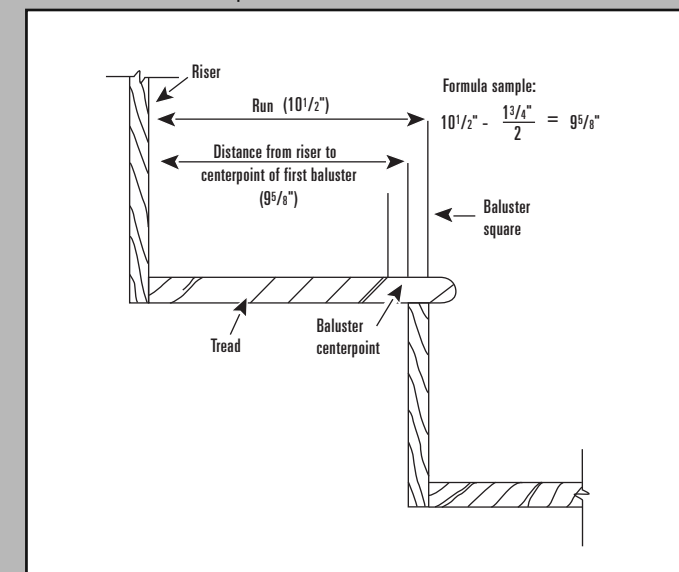
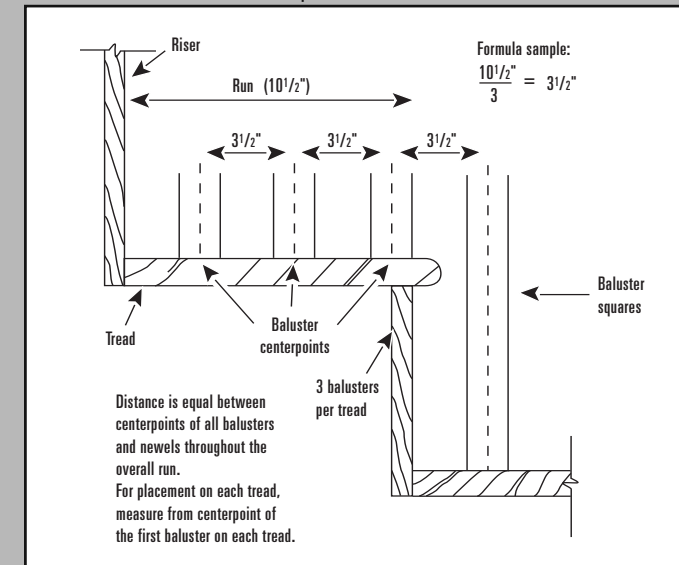

FIG. 8-6 - Second/third baluster position: mathematical method



## SECTION B

## SECTION B

STEP  
B.1b

## B.1b - Mark the Newel Positions

Newels are the primary support members of the balustrade. They should be placed at each point of stairway transition: the beginning ("starting newel"), at landings and balconies, and/or at the intersection of baluster lines where the stairway changes direction. Most codes allow 12' maximum spacing between newels on level balconies. Crown Heritage suggests 8' maximum spacing.

Newels should be positioned on the baluster line in exactly the same centerpoint position as the first baluster on a tread (see Fig. 8-1 and 8-4). (Newel position on a starting step is an exception, see Step B.3.) Since newels are larger in diameter than balusters (diameters vary depending on which Crown Heritage Collection you select), the newel must be notched to fit around the tread and riser to position it on its centerpoint (notching the newel is covered in Step B.3b).

## B.2 - All About Newels

Newels are turned from large-diameter lumber and designed for rigid attachment to the treads and/or stair carriage. Each of the two basic balustrade styles (post-to-post and over-the-post) have completely different newel designs.

## B.2a - Post-to-Post Newels

In post-to-post balustrades, the tops of the newels project above the handrail, and newels are always square in cross section at points where handrail or shoe rail will be joined to the newel.

The projecting (top) portion, or finial, usually features a decorative carving. Crown Heritage collections offer finials in the popular pineapple, mushroom, acorn, and ball top. Plain (chamfered) styles are also available.

Post-to-post newels come with flat bottoms (no dowels, see Fig. 9-1) and are mounted with a combination of horizontal lag bolts and vertical mounting screws. (Use Crown Heritage Hardware Kits nos. 3005, 3006, 3008, 3009/3019 and 3072.)

STEP  
B.2

FIG. 9-1 - Typical post-to-post newels

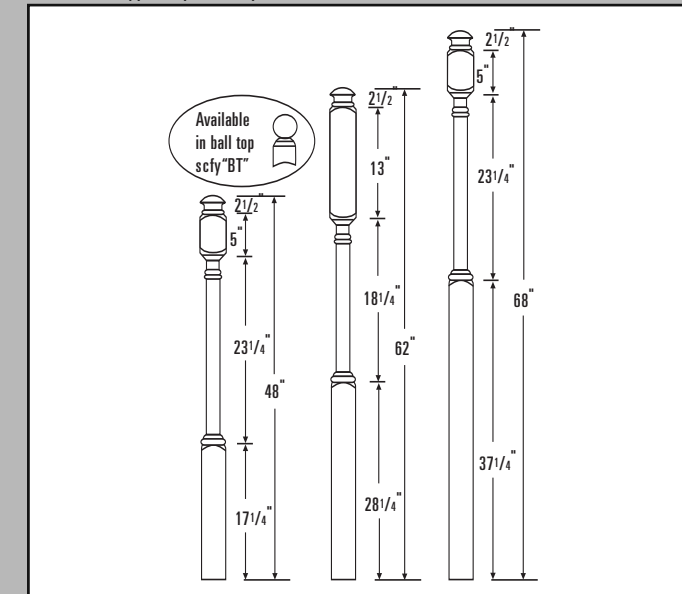

## SECTION B

## SECTION B

STEP

B.2a

*Universal Newel (48" long with a 5" Top Block)*

Choose this newel for a starting newel or first floor newel when your rake rail height is less than 33". This newel also can be used for level run or balcony installations when a 5" top block newel is desired.

*Universal Newel (54" or 56" long with a 5" Top Block)*

Choose this newel when your rake rail height is 34" or higher. This newel also may be used when fittings are used to gooseneck into the second floor newel or balcony newel. In addition, use this newel at the intermediate landing when a 5" top block newel and a gooseneck fitting are being used and the newel will not be draped over more than one rise. This newel also may be used as a level run or balcony newel when a longer drape is desired.

*Winder Newel (5" Top Block)*

Choose the longest 5" top block newel when the installation has winder or pie-shaped treads at the intermediate landing. This newel also may be used at the intermediate landing when a newel drop is being used.

*Intermediate Landing Newel (14½" Top Block)*

Choose the longest 14½" newel for all intermediate landings where fittings will not be used, and more than one rise is being draped. Only one intermediate newel is available in most collections.

*Intermediate Landing Newel (14½" Top Block)*

Choose the shortest 14½" newel for all intermediate landings where fittings will not be used and the newel will be face mounted to the first rise of the second flight of steps. This newel is not available in all collections.

*Second-Floor Landing Newel (11" Top Block)*

Choose this newel when the installation calls for a newel at the second floor or balcony and fittings will not be used.

## DETERMINE LENGTH OF A POST-TO-POST STARTING NEWEL

Typically, the rail connects to the top block of the newel so that there is a 1" reveal above the top of the rail on the flat surface of the top block. Therefore, make a mark at the desired reveal dimension. Now slide the newel on the floor along side of the treads until it is located exactly where it will be once it has been notched. Clamp a section of handrail on the tread nosing that extends down to the newel. At the intersection of the upper side of the newel base and the top of the handrail, transfer a mark to the newel base to indicate the location of the top of the handrail. Measure the distance between the two marks you have made and subtract the desired rake rail height. This is the amount that needs to be trimmed from the bottom of the newel. Make the appropriate notch.

## DETERMINE LENGTH OF A POST-TO-POST LANDING NEWEL

Draw a square representing the cross-section of the newel at the intersection of the two balustrades. Part of this square may be on the first tread of the upper flight. Mark the newel top block at the desired reveal in respect to the upper balustrade. Place the newel directly over the square you have drawn and then slide it to the side so that you can place a section of handrail on the tread noses. Mark the intersection of the upper face of the bottom block and the top of the rail on the bottom of the newel. Measure the distance between the marks. If the newel is to be draped, subtract the length of drape from this number. Now you have the amount that needs to be trimmed from the bottom of the newel. Notch appropriately and install.

## DETERMINE LENGTH OF A POST-TO-POST BALCONY NEWEL

Mark the newel top block at the desired reveal, typically 1", and then measure up from the bottom and mark the desired balcony rail height. Now measure the distance between these marks. This is the amount that needs to be trimmed from the bottom of the newel, exclusive of any drape. Traditionally the baluster centerline on a balcony, like that of a stairway, is found by aligning the front of the baluster square with the balcony fascia. Normally this requires that newels be notched. However, it is common for newels to sit completely on the second floor and not be draped. This means that the baluster line will be located further in from the outside edge of the balcony.

STEP

B.2a

FIG. 9-2 - Determining the length of a post-to-post starting newel

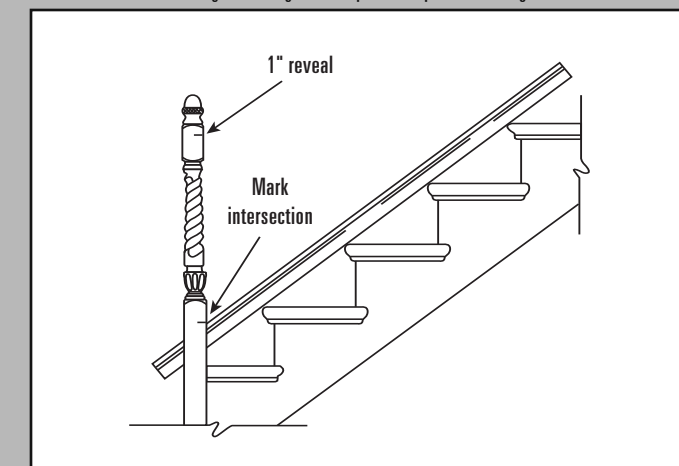

## SECTION B

## SECTION B

STEP

B.2b

FIG. 9-3 - Typical over-the-post newels

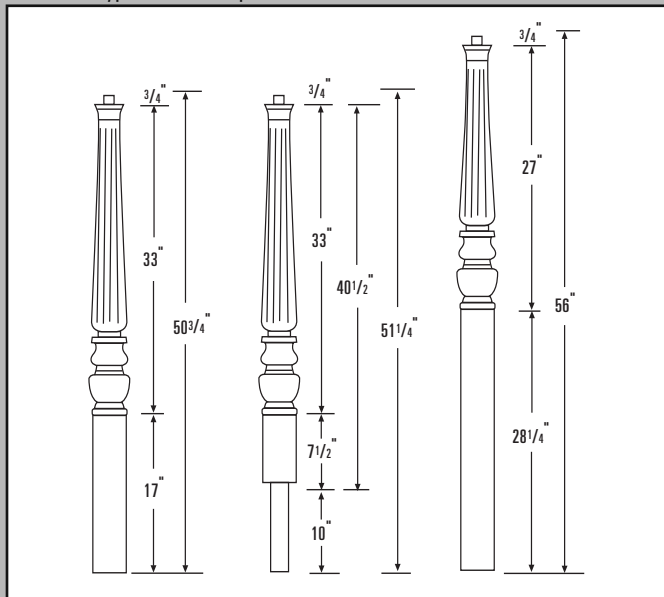

## B.2b - Over-the-Post Newels

Over-the post newels are always capped by the handrail. The top of each newel features a short dowel, and the lower end of some starting newel models features a longer dowel for mounting the newel on a starting step. Square bottom newels are also available (see Fig. 9-3). Square bottom over-the-post newels are mounted like post-to-post newels.

A variety of lengths and proportions are available in each of the Crown Heritage over-the-post newel styles (Williamsburg, 1800's, Crown and Colonial). Each is specially suited to the use of various available fittings as well as the geometry of landings.

STEP

B.2b

*Volute Newel with a Dowel Bottom*

This starting newel is used on a starting step when the installer of the stair system prefers this method of installation. These newels are available with a removable dowel, allowing the installer to shorten the block on the newel if a shorter rake rail height is desired. The shortest volute newel is used for 30" rake rail heights and the longest volute newel is used for 34" rake rail heights.

*Turnout Newel with a Dowel Bottom*

Turnout newels are available only in the Colonial Collection. Use this starting newel on a starting step when the installer prefers this method of installation. The newels come with a removable dowel, allowing the installer to lower the rake rail height if desired. The shortest turnout newel is used for 30" rake rail heights and the longest turnout newel is used for 34" rake rail heights.

*Universal Newel (43" long) Square Bottom*

This newel may be used on a starting step under a volute or turnout fitting and when the installer prefers to install Square Bottom newels. This newel also will allow the installer to vary the installation rake rail height easier than a volute newel. Also, use this newel on level runs or balconies where the installation is flush mounted or a one-rise drape is desired.

*Universal Newel (48" long)*

Choose this newel for the first floor or starting newel when a starting step is not being used, the rake rail height is 34" and a starting easing is being used. This newel also may be used when a longer drape is desired on a level run balcony.

*Intermediate Newel (56" or 58" long)*

Choose this newel for the intermediate landing newel and where long drapes are desired on a level run or balcony.

*Winder Newel (72" long)*

Use this newel on winder treads or pie-shaped treads at the intermediate landing. This newel also may be used at the intermediate landing when a newel drop is being used or a long drape is desired.

## SECTION B

## SECTION B

STEP  
B.2b

FIG. 9-4 - Determining the length of a starting newel

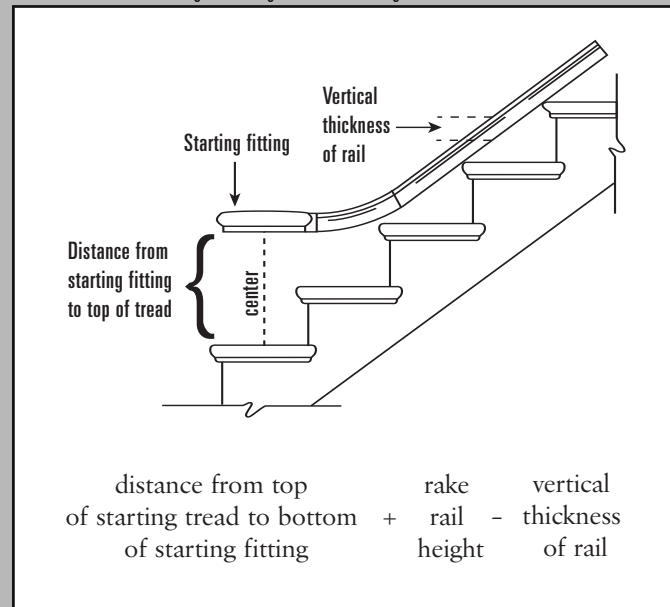

## DETERMINING LENGTH OF AN OVER-THE-POST STARTING NEWEL

In an Over-the-Post installation, the handrail must be assembled in order to calculate all the newel lengths. To calculate the Volute or Turnout Newel, simply center the hole in the bottom of the starting fitting over the center layout mark for the newel as indicated on the template that is supplied with the starting fitting. In order to do this, the volute or turnout should be attached to a section of straight rail so that the rail section can be clamped in place, resting on the noses of the treads and lined up on the balustrade centerline. Adjust the handrail/fitting assembly up or down the rake to achieve centering as described above. Now it is a simple matter to measure the distance from the starting tread to the bottom of the starting fitting. Add this dimension to the desired rake height and subtract the thickness of the rake rail, measured vertically, and you have calculated the length of the starting newel, exclusive of the top pin.

## DETERMINING LENGTH OF AN OVER-THE-POST LANDING NEWEL

To calculate the length of a landing newel, the hole in the bottom of the fitting must be centered over the intersection of the balustrade centerlines. With the appropriate gooseneck attached to a piece of straight rail extending up the second flight, clamp the assembly in place on the noses of the treads of the second flight. **Be sure and align the centerline of the assembly with the balustrade centerline on both flights.** Adjust the assembly up or down the rake until the hole in the bottom of the fitting is located precisely over the intersection of the lower and upper balustrade. Measure the distance from the landing to the bottom of the fitting. Add the rake rail height minus the thickness of the rail, measured on the plumb, and you have the length of the newel exclusive of the pin on the top and any drape or notching required.

## DETERMINING LENGTH OF AN OVER-THE-POST BALCONY NEWEL

The balcony newel length is calculated by taking the thickness of the rail from the desired balcony rail height. This gives the length of the newel exclusive of the pin on the top and any drape and notching required. If a drape is desired then the newel must be notched.

## STEP B.3 - Install the Starting Newel

See *StairNote Six: Starting Newels and Handrail Height*

## B.3a - Installing a Starting Newel in an Over-the-Post Stairway with a Bullnose Starting Step

In Step A.6, the starting step was assembled and dry fit to the stairway. Now place the template (supplied with the volute or turnout fitting) on the tread and on the baluster line (Step B.1a). Following the template instructions, mark baluster and newel positions.

Using the Crown Heritage Starting Newel Attachment Kit (#3072), install your newels. Locate the position of the newel on the starting step using the volute template. Then, using a  $\frac{7}{8}$ " drill bit, bore a hole through the tread. Attach the black metal plate to the bottom side of the tread using three screws.

Determine the length of the newel needed for your installation, and cut off the end of the square portion of the newel. Using the  $\frac{3}{8}$ " drill bit, bore a 5" hole in the center of the newel (see Fig. 10-1).

**WARNING:** It is critical that the hole be bored straight into the newel. If not done properly, the newel may lean.

STEP  
B.3a

FIG. 10-1 - Newel installation on a starting step

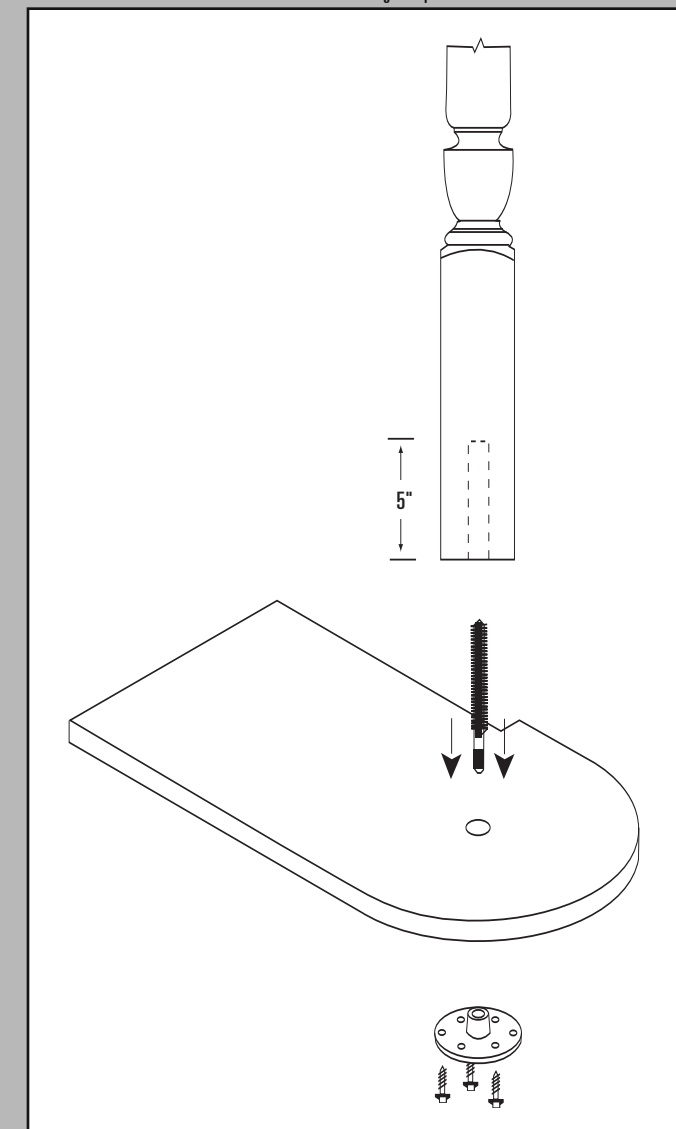

## SECTION B

## SECTION B

STEP  
B.3a

FIG. 10-2 - Alternate newel installation on a starting step

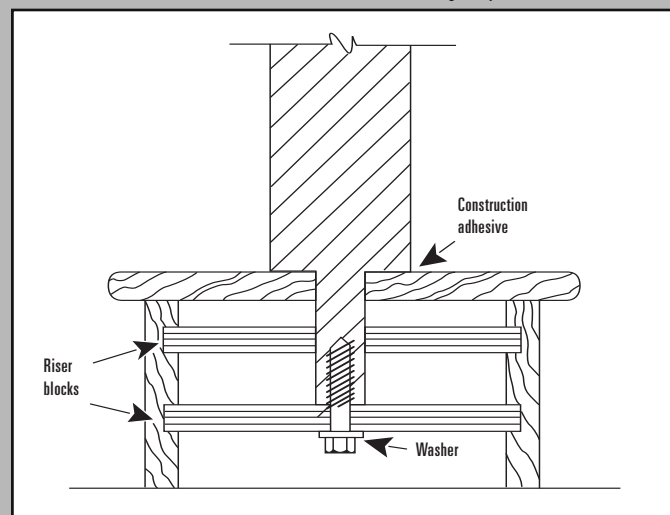

Install the wood screw end of the lag bolt into the hole using a ratchet or drill and socket. You may find it easier to lock two nuts together to make it easier to turn. The screw must penetrate the newel so that only 1" of the machine portion of the lag bolt is exposed at the bottom of the newel.

Mount the tread to the starting step riser as you normally would. Turn the machine screw end that is exposed on the bottom of the newel into the female portion of the metal plate that is attached to the bottom of the tread.

Hand tighten the newel to the top of the tread and square up the position of the newel so that it suits your installation.

Alternate Installation for dowel-bottom newels: Drill a hole for the dowel base of the starting newel. The hole should penetrate the tread and the first riser block inside the starting step. Insert the newel dowel until it rests on the lower riser block. Measure and remove the excess dowel length so the newel will be flush on the starting step, with the dowel resting on the lower riser block. Turn the starting step on its side and drill a  $\frac{3}{16}$ " hole through the lower riser block into the bottom center of the dowel to receive a  $\frac{1}{4}$ " x  $2\frac{1}{2}$ " lag screw.

Apply construction adhesive to the bottom of the newel at the point where it will come in contact with the tread. Mount the newel to the step using the lag screw and a washer large enough to cover the hole. Pull the newel down snug (see Fig. 10-2). Align it carefully before the adhesive starts to set and immediately clean up any excess adhesive.

Handrail height is defined as the vertical distance from the top of the handrail to the top of the leading edge of the tread (see Fig. S-6a). For accuracy, this measurement should be made at the fourth step. The length of the starting newel is the chief determinant of handrail height for the rake (angled) portion of the rail for the entire balustrade. CHECK LOCAL BUILDING CODE FOR HANDRAIL HEIGHT REQUIREMENTS. Currently, the IRC 2003 requires height to be not less than 34" and no greater than 38".

FIG.S-6a - Measurement of handrail height

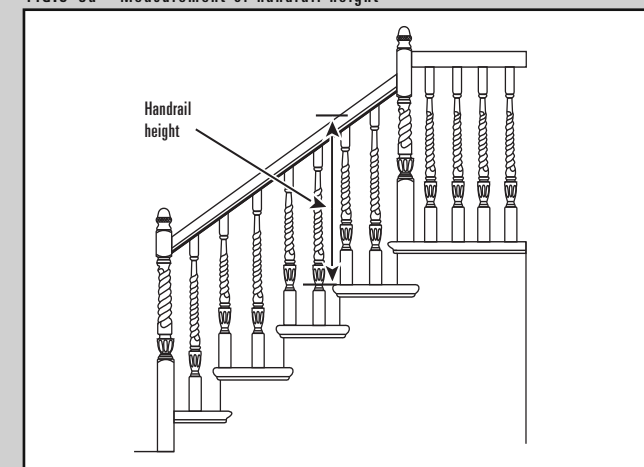

FIG. S-6b - Critical measurement points of starting newels

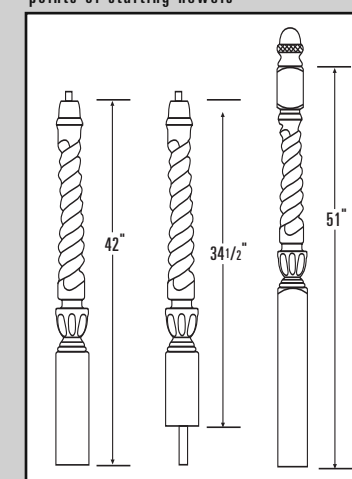

Fig. S-6b shows the critical measurement points of the three basic types of starting newels. If you are installing the Williamsburg Collection, you will need to carefully review *StairNote Seven: The Williamsburg Collection*.

## STAIRNOTE

## STARTING NEWELS

## SIX

## AND HANDRAIL HEIGHT

*NOTE: The complex geometry of stairway construction makes it impossible for Crown Heritage to guarantee precise installed handrail height for your stairway. The pitch of the stairway, style of fittings and rail you select, accuracy of trimming and connections, and centering the newel in places other than the "ideal newel position" can all result in slight variations in handrail height. We recommend you plan your balustrade to exceed building code requirements in all respects.*

Fig. S-6c shows how moving the starting newel away from the "ideal position" will affect handrail height. If your calculations show the rake handrail height of the stairway will be too low, this technique will allow you to increase it. On starting steps, it is best to position newels exactly as shown on the supplied template. Templates will be found in the volute or turnout fitting boxes.

FIG.S-6c - Impact on handrail height by moving starting newel

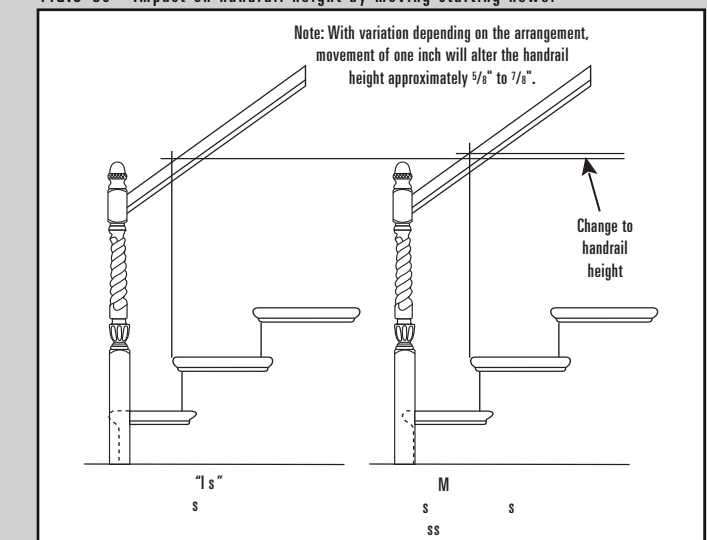

# SECTION B

# SECTION B

## STEP B.3b

FIG. 10-3 - Newel installation on a plain tread

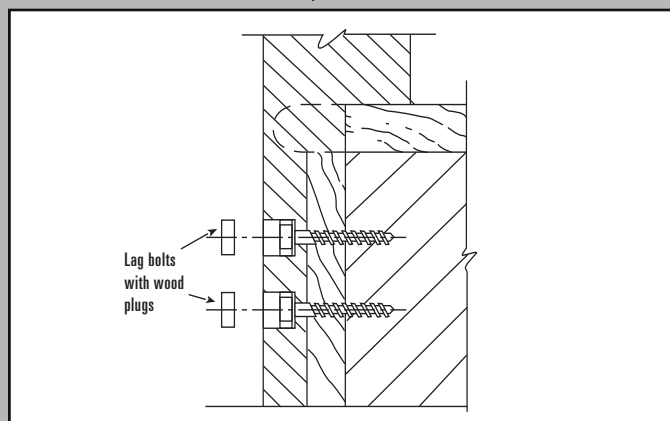

B.3b - Installing a Starting Newel in Over-the-Post or Post-to-Post Stairways with Plain Tread or Mitered Tread

If the starting newel is to be draped, the greatest care should be taken to notch the square base of the newel and the tread nosing for a snug fit. This is why the treads have been dry fitted to this point.

See *StairNote Eight: How to Notch A Newel*

See Step B.2 for instructions on determining the length of the starting newel. Use construction adhesive and Crown Heritage Rail/Post Fastener (part no. 3078) to permanently install the starting newel (see Fig. 10-3). Additional instructions can be found on the package (see Appendix 3).

If the newel is located flat on a tread, it should be installed using the Crown Heritage Newel Post Fastener (kit no. 3008) and following instructions on the package (see Appendix 3).

*NOTE: If you have selected Crown Heritage's Classic Collection for your balustrade, refer to StairNote Eleven: The Classic Collection: Breaking All the Rules, page 43.*

## STEP B.3b

### STAIRNOTE

### HOW TO

### NOTCH A NEWEL

## EIGHT

### STAIRNOTE SEVEN THE WILLIAMSBURG COLLECTION

FIG. S-7a - Proper height alignment for Williamsburg newel (plain tread installation shown)

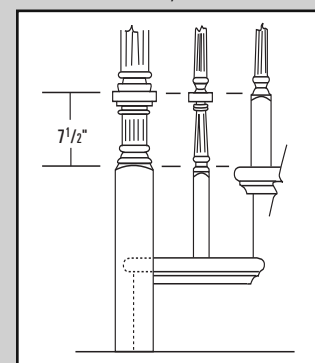

A successful installation of the Williamsburg Collection adds another consideration to the planning of your rail heights. The architectural square of the newel, architectural square of the balusters, and tread must be aligned to create the full visual effect of the Williamsburg Collection. This alignment is achieved by setting the newel so the architectural square is 7 1/2" above the second tread (see Fig. S-7a). Rail heights must be planned with this requirement in mind. It is recommended that the Williamsburg Collection only be used in installations where the rise is 7 1/2" +/- 1/4".

Throughout the Williamsburg balustrade the architectural square of the balusters, the top of the lower square of the next set of

FIG. S-7b - Alignment of Williamsburg balustrade

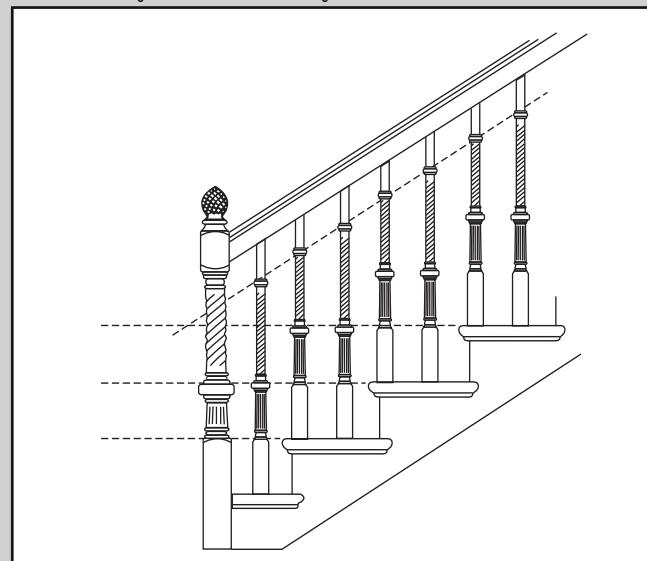

balusters, and the bullnose of the next higher tread are to be aligned horizontally, as shown in Fig. S-7b. Proper alignment of the squares creates a visually extended horizontal plane leading from the stair. This effect increases the balustrade's elongated, graceful and elegant appearance.

As noted in Step B1b, a newel should be centered on the baluster line in exactly the same centerpoint position as the first baluster on a tread (see Fig. 8-1 and 8-4).

Except on starting steps, this usually means draping the newel over the riser and the stringer. Draping adds to both the aesthetic and structural qualities of your stairway. Draping a newel requires notching the newel and the tread nosing to precise dimensions. To avoid mistakes, follow these two notching rules:

**RULE NO. 1:** Before you cut into one of your newels, practice marking and notching a piece of scrap material such as a 4 x 4.

**RULE NO. 2:** Rough cut the notch, leaving 1/4" all around. Be sure you have the correct geometry, then finish the notch by paring away the extra material.

FIG. S-8a - The 1-way notch

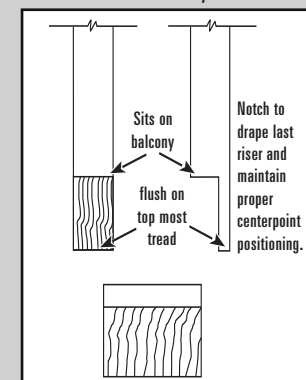

FIG. S-8b - The 2-way notch

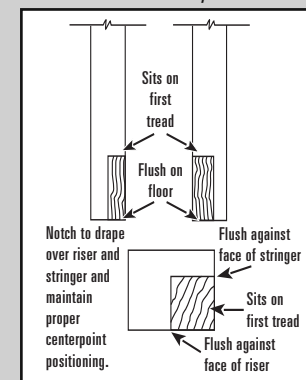

FIG. S-8c - The compound notch

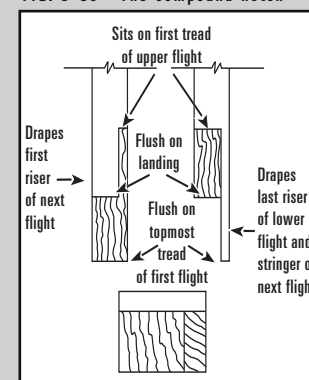
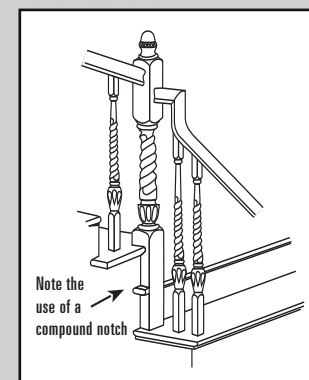

FIG. S-8d - Typical landing newel installation



The 1-way notch (Fig. S-8a) is often used on balconies. It allows the balcony newel to sit on the balcony and drape over the face of the balcony.

The 2-way notch allows a starting newel to sit on the floor as well as the first tread of the stairway, while draping the riser and stringer (Fig. S-8b).

The compound notch is really two adjoining notches and is usually found on stairway landings where there is a change in stairway direction (Fig. S-8c). A compound notch allows a landing newel to sit on two treads and drape two risers in addition to the stringer.

Fig. S-8d shows a typical landing installation. Note the tread nosings have been notched to receive a newel with a compound notch.

## SECTION B

## SECTION B

STEP  
B.4

## STEP B.4 - Install the Starting Step

Go to Step B.5 when using plain tread for the first step.

Apply adhesive to the floor cleat installed in Step A.6 and to the back edge of the starting step tread, and move the assembly into its final position. A few 8d finishing nails through the riser will hold it to the cleat while the adhesive sets. Where possible, use screws to attach the second riser to the back of the starting step tread.

## STEP B.5 - Install the Remaining Treads

See *StairNote Nine: Squeakless Stairways*

In Step A.7 the treads were dry fitted. Permanently install the treads, beginning with the first plain tread or mitered tread. (When you are using a starting step, the first plain tread is the second step.) Apply construction adhesive to the stringers, then apply carpenter's wood glue to the top edge of the first riser and the back edge of the tread (see Fig. 12-1).

If you have access to the underside of the stairway, secure the tread to the cleats, if used, with screws. Also, place screws through the bottom of the riser to secure the back edge of the tread (see Fig. 12-1).

If you do not have access to the underside of the stairway, reach through the open space for the next tread to secure the tread to the cleats and riser with screws.

If you do not use cleats (*StairNote Nine: Squeakless Stairways*), nail down through the face of the tread. Use 10d or 12d finish nails, and nail into each stringer, ensuring the tread is pulled flat. Countersink the heads so they can be filled later. Another installation option is to drill for wood plugs and use screws instead of nails.

Repeat these instructions for all remaining treads.

STEP  
B.5

FIG. 12-1 - Permanent installation of treads

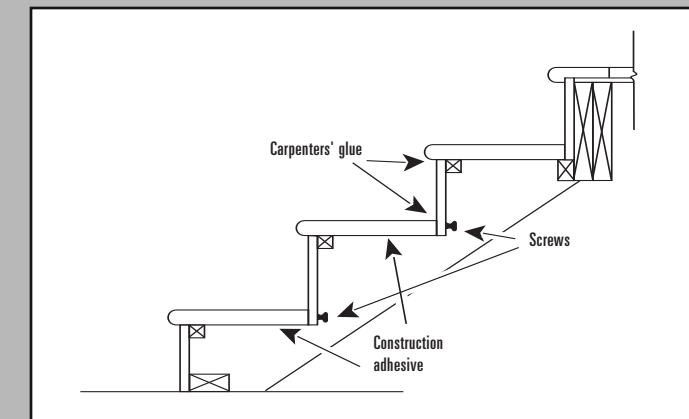
STAIRNOTE  
NINE  
SQUEAKLESS  
STAIRWAYS

The use of cleats in staircase construction will provide extra sturdiness. Before permanently installing stair treads, use carpenter's glue to attach square cleats (approximately 1 1/4" x 10") flush with the top edge, and on the backside, of each riser. Cleats must be centered between stringers (see Fig. S-9).

Construction adhesive at the joints between stringers/risers and treads, and carpenter's glue on cleated joints between risers and treads will help assure a sturdy, "squeakless" installation.

FIG. S-9 - Installation of cleats

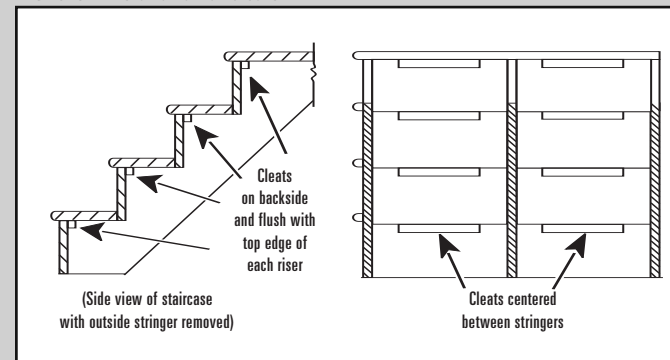

## SECTION B

## SECTION B

STEP  
B.6

FIG. 13-1 - Landing newel location

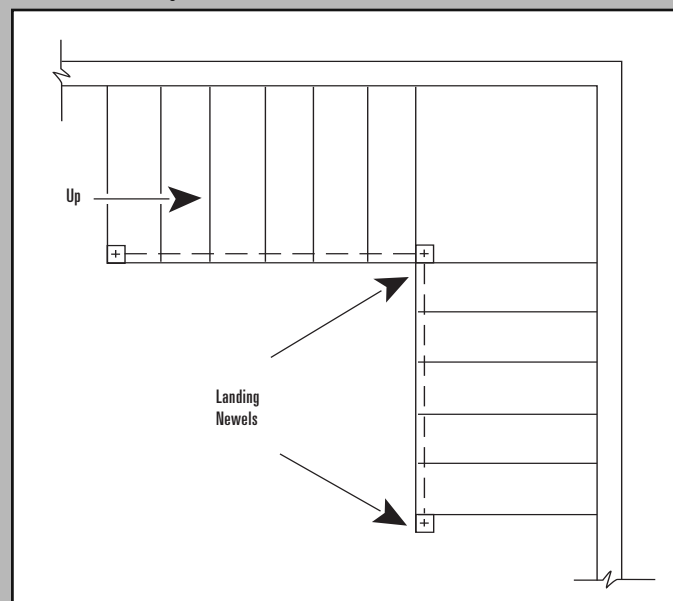

## STEP B.6 - Install the Landing Newel(s)

The landing newel, like the starting newel, must be positioned on the baluster line (Step B.1a). When your stairway changes direction at a landing, the landing newel must be positioned at the intersection of two baluster lines (see Fig. 13-1).

The Crown Heritage System includes special landing newel designs for both post-to-post and over-the-post stairways that adapt to the various geometric requirements your design may demand. Landing newels differ from starting newels in the relative proportions of the bottom square portion, the central carved or decorative portion, and the portion to which the rail will be attached (“top square”). Refer to the catalog for illustrations and dimensions of the various newel types.

See Step B.2 for detailed instructions on determining the length of the landing newel. To maintain consistent handrail height on the second flight of steps when the rise and run are the same, calculate the landing newel length like the starting newel length for post-to-post installations or starting newels using a starting easing. When the handrail of the first flight begins with a volute or a turnout, the landing newel length must be calculated the same as the length of a starting newel positioned on the first step at the face of the second riser.

Once the landing newel has been sized and notched, mount it to the stair using the same methods and hardware as described for starting newels.

STEP  
B.7

## STEP B.7 - Install the Balcony Newel(s)

As noted in *StairNote Six: Starting Newels and Handrail Heights*, local building code requirements should be checked before you plan the height of a balustrade. Safety and utility usually call for a balcony handrail height of at least 36" for residential and 42" for commercial stairways.

See Step B.2 for detailed instructions on determining the length of the balcony newel. Calculating the newel length for a level balcony rail is easy: in over-the-post installations, just subtract the level handrail thickness from the total desired handrail height to obtain the length of the newel body, not including the part of the newel that drapes down below the balcony floor level. Do not include the top dowel pin in newel length.

If the first balcony newel is to be draped and notched against the last riser of the stairway, the distance from the finished surface of the balcony floor to the top of the last tread must be added for the total newel length. Plan to mount one newel for each 8' of balcony run.

Traditionally, the baluster line on a balcony, like that of a stairway, is found by aligning the front of the baluster square with the balcony fascia. Balcony newels should be notched and anchored like starting/landing newels (see Step B.3b).

## SECTION B

## SECTION B

STEP  
B.8

FIG. 15-1 - Installation of half newel

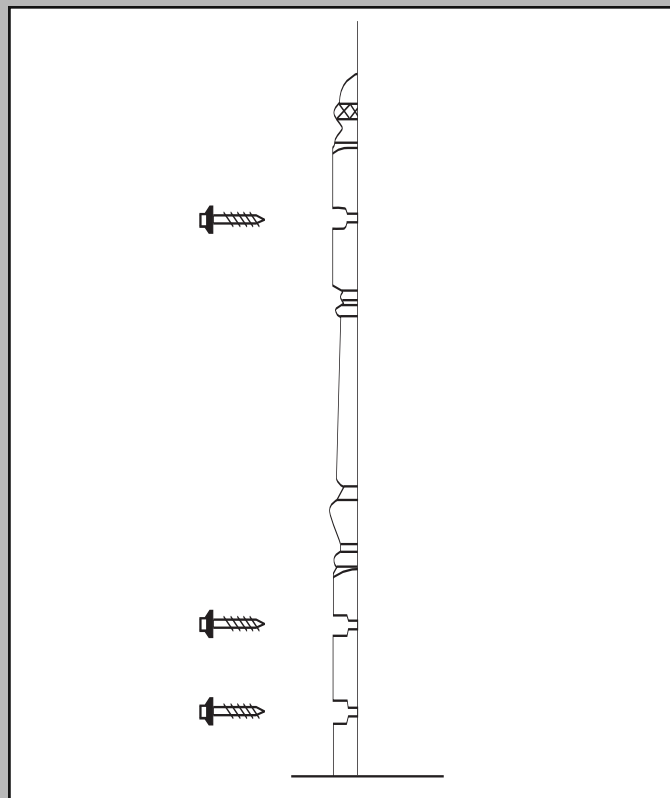
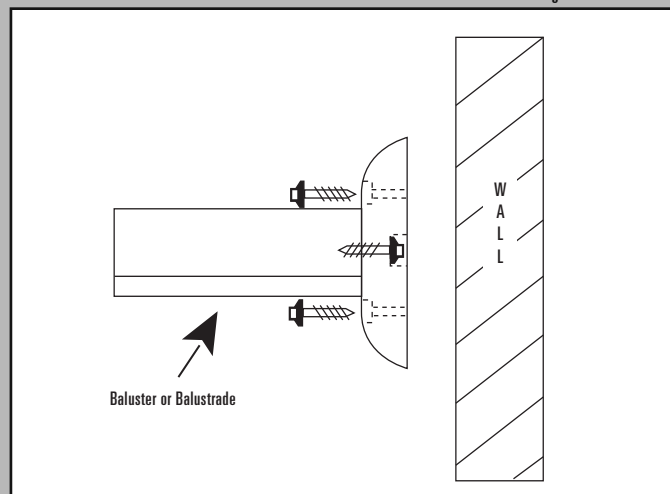

FIG. 15-2 - Rosette mounted at the termination of a balustrade against a wall



## STEP B.8 - Install the Half-Newel or Rosette

The use of a half-newel where the balustrade terminates into the wall will give your stairway a far superior appearance. To use a half-newel, locate the half newel on the baluster line and cut it to the same length as other newel(s) in the run. Install as shown in Fig. 15-1, using rail/post fasteners (Hardware Kit no. 3078). Exposed bolt holes should be covered with the plugs provided.

A rosette is an alternate means of terminating a balustrade. **DO NOT MOUNT THE ROSETTE NOW.** It will be mounted on the end of the handrail in the next step (B.8) and screwed to the wall as shown in Fig. 15-2. During final assembly, bore pilot holes for two 3" drywall screws, then countersink them and plug the holes. If no stud is positioned to receive the nails, use countersunk toggle bolts and construction adhesive to mount the rosette. Plug the holes during final assembly.

## STEP B.9 - Assemble and Dry Fit the Handrail

Now it is time to put your pitch block (see *StairNote Three: How to Make a Pitch Block*) to use in constructing the handrail.

In completing this step, remember that even the best carpenters do not attempt complex angle cuts in one step. We advise that you:

- (1) rough cut to an inch or so oversize;
- (2) cut again to about  $\frac{1}{4}$ " oversize to make sure the angles are right; and
- (3) then make a final "precision" cut to finish size.

## STEP B.9a - Over-the-Post Handrail

## STARTING FITTINGS - VOLUTES, TURNOUTS AND STARTING EASINGS

Use a pitch block to determine the location and angle of the necessary cut. Place the fitting on a flat surface and clamp so that the flat bottom portion of the fitting is in full contact with the flat surface. Place the pitch block on its "run" side and slide the "rake" edge up to the underside of the up easing until it barely makes contact. Be sure to keep the pitch block in line with the projected centerline of the handrail. Make a mark at the tangent point (the point where contact is first made). Now flip the pitch block over on its "rise" side and slide it up along side of the fitting with the "rake" edge facing the uncut end of the fitting. Align the "rake" edge with the tangent point mark and draw a line that transfers the "rake" edge to the fitting. This is the cut line (see Fig. 16-1).

Typically, this cut is made on a miter saw, a sliding miter saw or a radial arm saw. With the flat surface of the fitting held at the "rake" angle, the fitting is adjusted until the cut line is aligned with the saw blade. The pitch block can be clamped to the fence of the saw to provide support for the flat surface of the fitting.

STEP  
B.9a

FIG. 16-1 - Use of a pitch block for proper cutting of easing

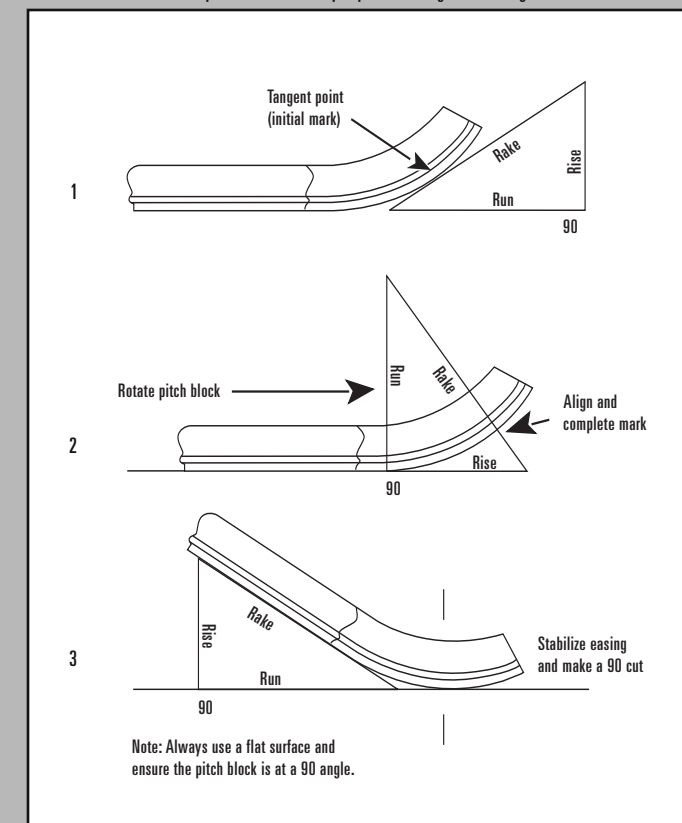

## SECTION B

## SECTION B

STEP

B.9a

FIG. 16-2 - Marking the gooseneck for trimming

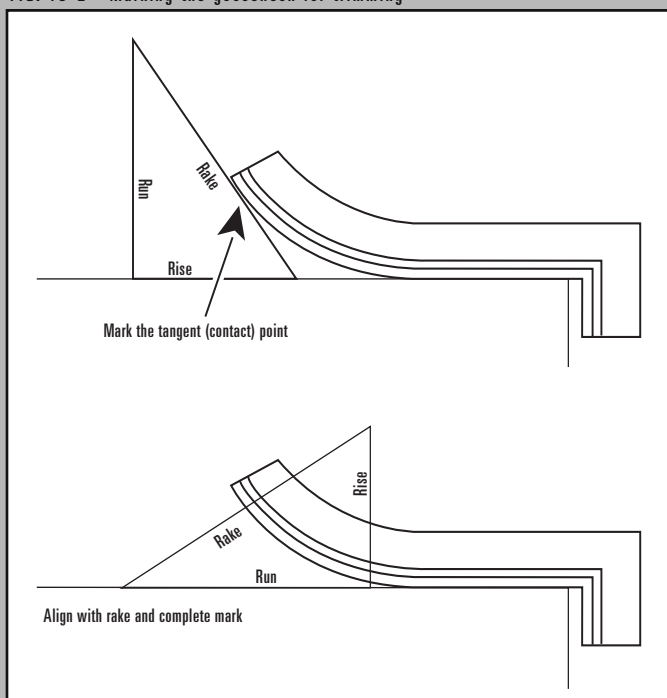

## GOOSENECK LANDING FITTINGS

These fittings consist of a loose up easing and a transition piece that has an attached up easing on the upper end. Trim the transition up easing first just as described in the Starting Fitting section. Then join the upper section of rail to the trimmed end of the transition piece. This assembly is then clamped to the tread noses, centered on the balustrade centerline. Then slide the assembly up or down the rake until the hole in the bottom of the fitting is centered at the intersection of the upper and lower balustrade centerlines.

The lower up easing needs to be attached to the lower rail before it can be marked properly. With the handrail on a flat surface, place the pitch block on its "rise" side and slide the "rake" edge up to the underside of the up easing until it barely makes contact. Make a mark at this point. (An alternate way of finding the tangent point is to place the rail assembly on the nose of the treads, centered on the balustrade centerline, and slid it up the rake until the up easing comes in contact with the rail-drop of the transition piece that it is clamped on the upper flight. The point where contact is made is the tangent point.) Place the pitch block on the "run" edge and slide it along side of the up easing with the "rake" edge facing the uncut end of the up easing. Align the "rake" edge with the tangent point and draw a line that transfers the "rake" edge to the fitting. This is the cut line (see Fig. 16-2).

Once cut, this section is placed back on the tread noses and moved over from the balustrade centerline just enough to allow the lower assembly to pass by the rail-drop of the transition piece. Slide the lower assembly up the rake until the back of the lower up easing is flush with the back of the rail-drop. Make a mark at the top of the up easing on the rail drop and then cut the rail drop. The lower assembly is now ready to join to the upper assembly.

STEP

B.9a

## BALCONY GOOSENECK FITTINGS

These fittings come in 1-rise and 2-rise variations. The 2-rise has a loose up easing. The up easing in the 1-rise variation is factory-attached. To trim a 1-rise gooseneck, place the fitting so that the rail-drop portion that is attached to the up easing lies on a flat surface. This will likely require that the top part of the fitting hang off of the flat surface. Place the pitch block on its "rise" side and slide the "rake" edge up to the underside of the up easing until it barely makes contact. Make a mark at this point. Place the pitch block on the "run" edge and slide it along side of the up easing with the "rake" edge facing the uncut end of the up easing. Align the "rake" edge with the tangent point and draw a line that transfers the "rake" edge to the fitting. This is the cut line. The pitch block may be used as a support while making the angled cut (see Fig. 16-2).

The 2-rise gooseneck consists of an up easing and a transition assembly. The transition assembly must first be attached to the balcony rail. Then the balcony rail section must be placed so that it is aligned with the balcony balustrade centerline and the hole in the bottom of the transition assembly is centered over the balcony newel location. This whole assembly must also rest on temporary blocks so that when the rake rail is placed on the noses of the treads, the balcony rail will be in the correct relative position. Use the following formula to calculate the height of the temporary blocks:

$$\text{block height} = \text{balcony rail height} - \left( \text{rake rail height} - \text{thickness measured on the plumb} \right) - \text{balcony rail thickness}$$

## SECTION B

## SECTION B

STEP  
B.9a

With the balcony assembly aligned as described above and resting on the blocks, the rail drop portion of the transition assembly will now be aligned with the rake balustrade centerline. Since a fitting of some sort is already attached to the lower end of the rake rail, it is necessary to determine the proper length of the rail and the correct angle to cut the up easing. Cut the rake rail to length so that when placed on the nose of the treads, aligned with the rake balustrade centerline and with the hole in the lower fitting centered over the lower newel location, the rail is approx.  $\frac{1}{4}$ " short of the rail drop. Now use a tri-square and the up easing to mark the cut line on the handrail. Place the tri-square on under side of the rail, with the blade pointed up, and push the end of the up easing against the blade while flushing the bottom of the up easing with the bottom of the rail. Now slide the tri-square/up easing up the rail until the upturned bottom of the up easing is flush with the bottom of the rail drop. Hold the tri-square in place while you remove the up easing. Now scribe a mark along the blade of the tri-square. This is the cut line.

To cut the upper end of the up easing, first attach it to the rake rail. Now, with the handrail on a flat surface, place the pitch block on its "rise" side and slide the "rake" edge up to the underside of the up easing until it barely makes contact. Make a mark at this point. Place the pitch block on the "run" edge and slide it along side of the up easing with the "rake" edge facing the uncut end of the up easing. Align the "rake" edge with the tangent point and draw a line that transfers the "rake" edge to the fitting. This is the cut line (see Fig. 16-2).

The last thing to do is mark and cut the rail drop. Place the rake rail, with the up easing attached, on the nose of the treads, aligned with the rake balustrade centerline. Move the rail assembly over to allow the upper end to slide past the rail drop. When the attached up easing is flush with the back of the rail drop, mark the rail drop at the top of the up easing. This is the cut line.

B.9b - Post-to-Post Handrail  
(for over-the-post systems, go to B.9a)

Begin by checking all newels (and end walls) to be sure they are plumb. Locate the position of the top edge of the handrail on the top square of each newel as shown in Fig. 16-4. (If you are using a landing newel with a 10" or 13" to 13 $\frac{1}{2}$ " top square, clamp the rail in position on the starting newel and landing newel to assure consistent rake rail height.)

Clamp a section of handrail across the tread nosings as shown in Fig. 16-5. Mark the handrail cuts directly from the bottom squares of the newels.

Cut approximately  $\frac{1}{8}$ " long and dry fit to the installed newels. Trim as appropriate. Fasten the rail to the newel post using Crown Heritage Rail & Post Fastener (#3078) per instructions on the package.

STEP  
B.9b

FIG. 16-3 - Positioning handrail on post-to-post top square

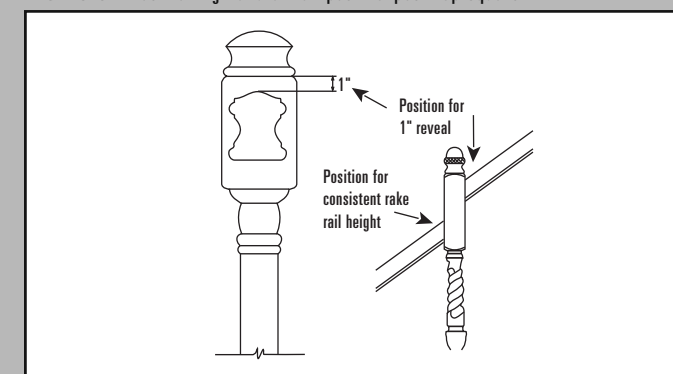
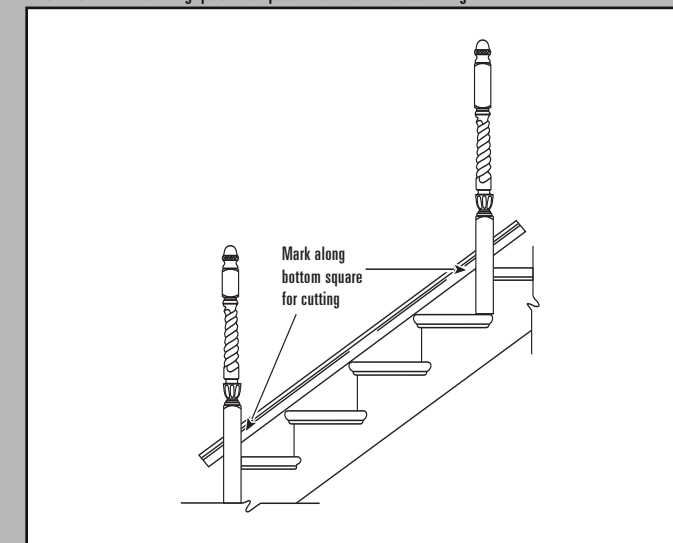

FIG. 16-4 - Marking post-to-post handrail for cutting



## SECTION B

## SECTION B

STEP  
B.10

FIG. 17-1 - Crown System alignment

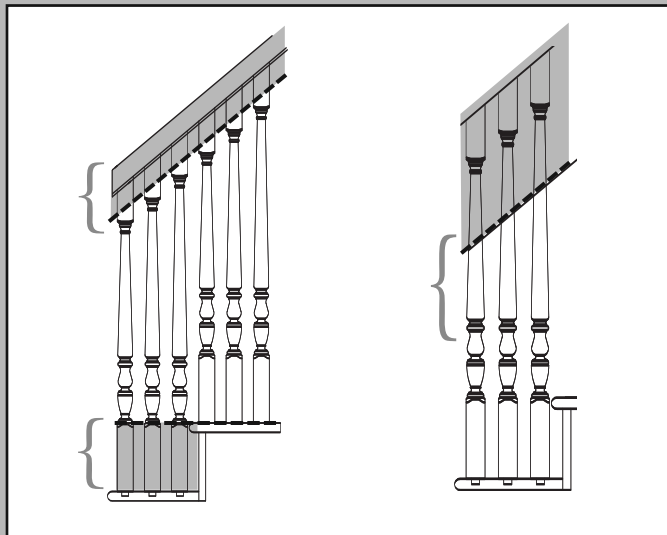
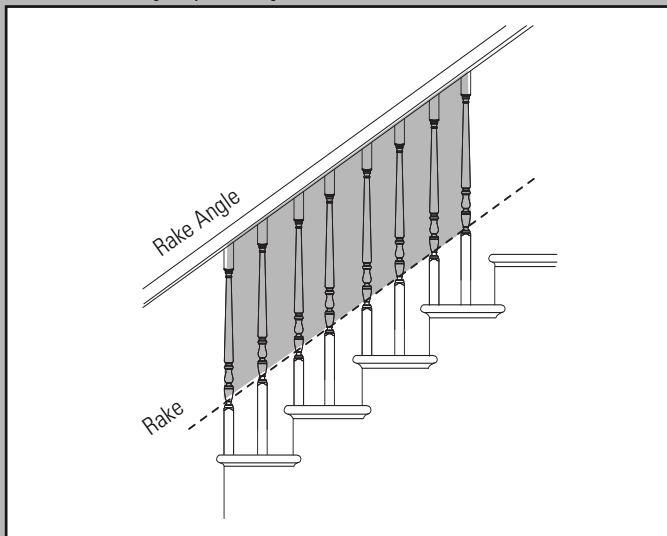

FIG. 17-2 - 3-length system alignment



## STEP B.10 - Install the Balusters

In Step B.1a, you marked the centerpoints of all the balusters on the baluster line. Now with newel(s) and handrail dry fitted, it is time to dry fit the balusters. See *StairNote Ten: All About Balusters* for a better understanding of baluster features.

For dowel bottom balusters, begin by drilling  $\frac{3}{4}$ " diameter holes  $\frac{7}{8}$ " deep in the treads at the baluster centerpoints. Flat bottom balusters are designed for use with shoe rail.

**WARNING: Avoid drilling through the tread when using dowel bottom balusters, since this compromises the strength of the glue joint at final installation.**

## Crown System (see Fig. 17-1):

The System is available in standard lengths. For the  $\frac{1}{4}$ " balusters, those lengths are 35", 37 $\frac{1}{2}$ ", 39" and 44". For the  $\frac{1}{4}$ " balusters, those lengths are 31", 35", 37 $\frac{1}{2}$ ", 39" and 42". In most areas, the building codes require a 34" rake height and a 36" balcony or guardrail height. *Please note that these balusters are designed to be cut at the top when installed.*

**For 34" or 35" rake heights:** Using two balusters on the tread, choose the 35" baluster as the first baluster and the 39" baluster as the second baluster. When using three balusters on a tread, choose the 35", 37 $\frac{1}{2}$ " and 44" balusters (or use the 42" baluster if you are using  $\frac{1}{4}$ " balusters). The top of these balusters will need to be trimmed up to 1 $\frac{1}{2}$ " to lower the rake rail to approximately 34" and/or to fit under the rail.

## Balcony Balusters

Choose the 35", 37 $\frac{1}{2}$ " or 39" balusters depending upon the height you would like to achieve on the balcony. Remember that a 35" baluster will achieve a balcony height of 36" and is code compliant in most areas.

## Starting Fitting Balusters

When using  $\frac{1}{4}$ " balusters and for 34" and 35" rake heights, use 42" balusters under volutes and turnouts. When using  $\frac{1}{4}$ " balusters and for 34" and 35" rake heights, use the 44" balusters under climbing volutes, regular volutes and turnouts.

## 3-Length System (see Fig. 17-2):

The 3-length system aligns the bottom baluster squares with the rake of the rail. All balusters must be trimmed to length from the bottom.

## For 34" to 38" rake heights and two balusters per tread:

For 34" to 35" rake heights, use a 34" first baluster and a 38" second baluster. For 35" to 38" rake heights, use a 38" first baluster and a 42" second baluster.

## For 34" to 38" rake heights and three balusters per tread:

For 34" to 35" rake heights, use a 34" first baluster, a 38" second baluster and a 42" third baluster. For 35" rake heights, use a 38" first baluster, and 42" second and third balusters. When installing **three** balusters on a tread *and* using the 3-Length System, at least two of the bottom baluster squares will need to be trimmed for proper alignment. **Warning:** At a 35" to 38" rake height, the 42" baluster may not be long enough to use under gooseneck fittings.

## Balcony Baluster

Use 38" balusters to achieve 36" balcony rail heights and 42" balusters for 42" balcony rail heights.

## Starting Fitting Baluster

For 34" to 36" rake heights, use 42" balusters under the volute and 42" balusters under turnouts. Climbing volutes requirements are 38" and 42" balusters for 34" rake heights; and 42" balusters for 36" rake heights.

STEP  
B.10

## STAIRNOTE

## ALL ABOUT

## TEN

## BALUSTERS

FIG. S-10 - Typical balusters "square top" and "pin top"

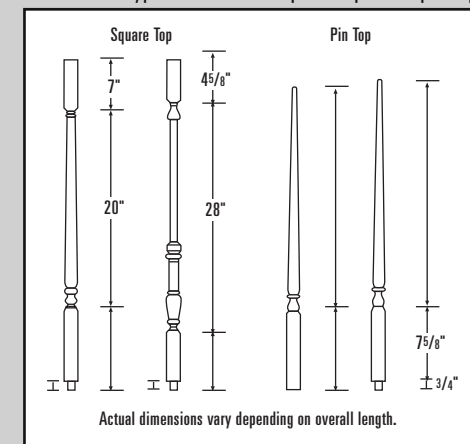

The primary role of balusters is safety: they keep people and objects from going through the balustrade. Secondly, balusters support the handrail and add beauty to the stairway.

## SQUARE TOP OR PIN TOP?

There are two types of balusters available in the Crown Heritage System: "square top" and "pin top" (see Fig. S-10). The Williamsburg, 1800's, Carolina, Colonial, and Hampton Collections all offer square top designs, which are meant to be used with "plowed" handrail. (Classic balusters are square too, but they are designed for face mounting on their rails. Refer to *StairNote Twelve: The Classic Collection: Breaking All The Rules* for instructions about the special uses of this design.)

The "pin top" balusters, designed to be inserted like dowels into the handrail, are available in all collections except the Classic.

## BUY THE RIGHT LENGTH

Finally, balusters come in a wide array of lengths, ranging between 31" and 42". This is to accommodate differing handrail heights as well as the special triangular geometry of open stairways.

## SECTION B

## SECTION B

STEP

B.10a

FIG. 17-3 - Marking pin top baluster centerpoints on handrail

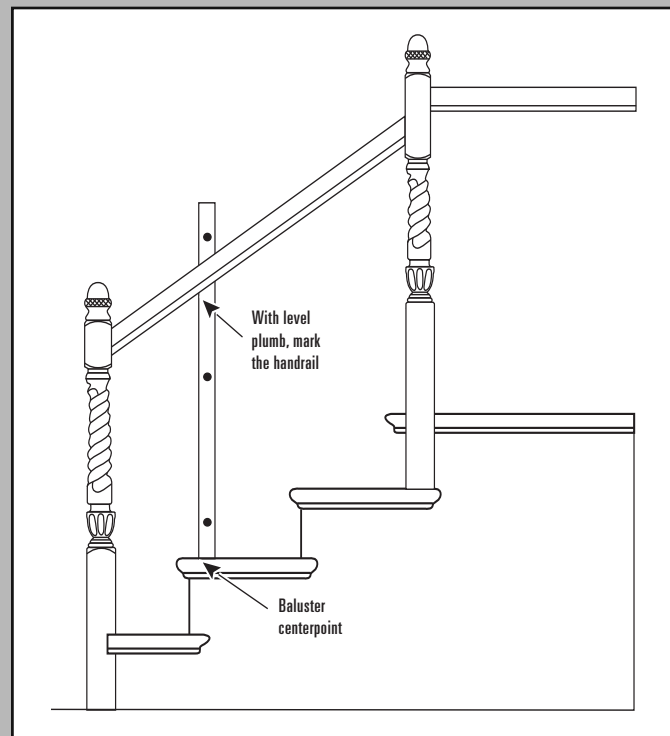
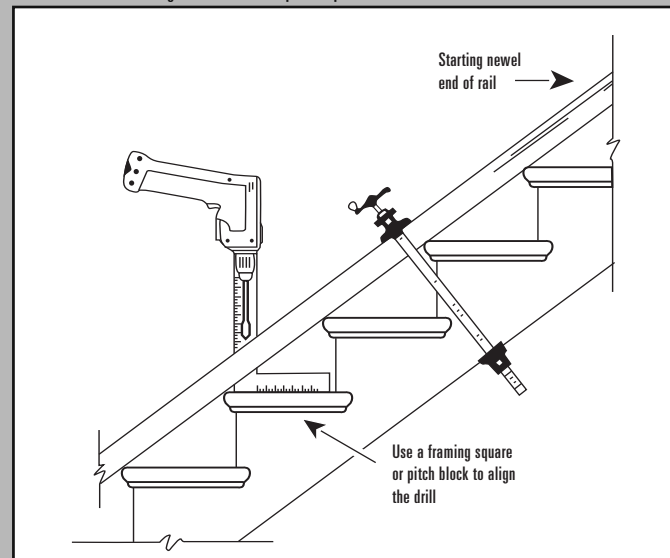

FIG. 17-4 - Drilling handrail for pin top balusters



## B.10a - Installing Pin Top Balusters

Pin top balusters are designed to fit into a hole drilled in the underside of an unplowed rail. The object is to find the centerpoints for these holes on the underside of the rail and to be certain the balusters will be plumb.

Use a carpenter's level to transfer the baluster centerpoint on the tread to the underside of the handrail that was dry-fit in Step B.9 (see Fig. 17-3). Mark each baluster centerpoint.

Carefully measure baluster lengths. Do not include mounting dowels at the base of the baluster in your measurement. Add 1" for the depth the top of the baluster will penetrate into the handrail. Remember the second (and third) balusters on a tread are longer than the first.

Check baluster length on another tread at the end of the flight. The lengths should be the same. If they are not, the rail is not parallel to the rake of the stairway. Go back to Step B.8 and adjust the rail.

Complete the measuring and cutting of balusters for the entire stairway. Carefully compare and inventory all parts to assure yourself the system is complete.

De-mount the rail and clamp the straight section across the tread nosings (see Fig. 17-4). You may remove any fittings to do this. They will be permanently reattached to the rail in the next step. **Rotate the rail and flip over, putting the starting newel end at the top of the flight.** Using the pitch block or a framing square to help keep the drill bit perpendicular to the treads, drill  $\frac{3}{4}$ " diameter holes  $\frac{5}{8}$ " deep in the center of the handrail.

STEP

B.10b

## B.10b - Installing Square Top Balusters

Square top balusters are designed to fit into the groove or "plow" in "plowed" handrail. Using a carpenter's level, find the location of the balusters on the handrail (see Fig. 17-5). Mark the intersection of the upstairs face of the top square of the baluster on the handrail.

Carefully measure baluster lengths. Do not include the mounting dowels (the plow is  $\frac{1}{4}$ " deep). Remember the second (and third) balusters on a tread are longer than the first.

Check baluster length on another tread at the end of the flight. The lengths should be the same. If they are not, the rail is not parallel to the rake of the stairway. Go back to Step B.8 and adjust the rail.

Use the pitch block to mark the angle of cut on the top square. Follow the philosophy outlined at the beginning of Step B.8, rough cutting and checking angles before making the final cut.

Complete the measuring and cutting of balusters for the entire stairway. Carefully compare and inventory all parts to assure yourself the system is complete.

The fillet, pre-packaged with the rail, will be trimmed and installed in the next step.

FIG. 17-5 - Marking square top baluster locations

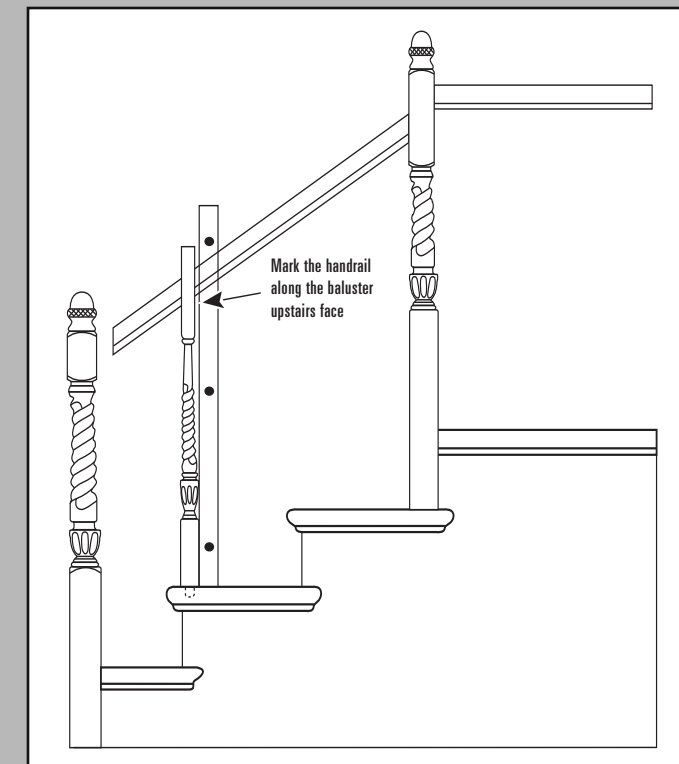

## SECTION B

## SECTION B

STEP

B.10c

FIG. 17-6 - Forged iron creative samples

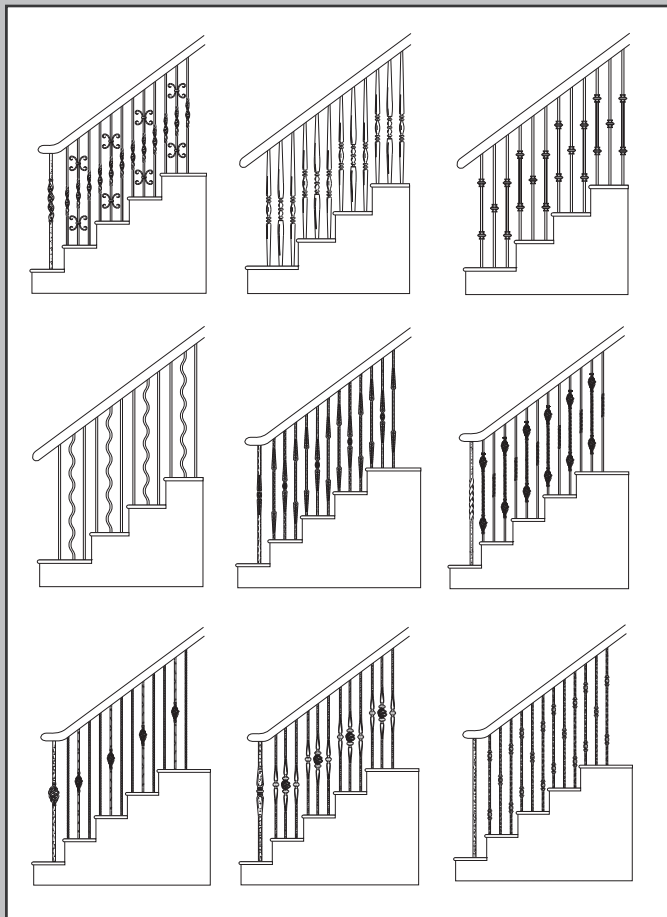

## B.10c – Installing Forged Iron

Here's your chance to be creative. Our forged iron stairways may be designed to your preference. Feel free to "mix and match" balusters that appeal to you. Almost any combination is acceptable. Our graceful "belly balusters" are specially designed for balconies. They are a great way to make your stairway unique! Forged iron newels may be used in Over-the-Post installations. Consider combining wood with forged iron balusters, they make a beautiful stairway. See Fig. 17-6 for some creative suggestions.

Many building codes require three balusters on a tread. Check with your local code officials if you have any doubts about compliance.

Because these balusters are handcrafted, they may vary slightly in size. Please check each baluster and newel before you drill the hole for it.

Our standard 44" length balusters will accommodate most situations.

Cut all balusters from the bottom. This ensures proper alignment of the design elements.

Balusters are offered in both square and round shapes and may be installed with or without shoes. Each requires that the appropriately-shaped hole be cut in the tread and handrail. One way to cut the square hole is by drilling a round hole in the wood the same size as the baluster's overall width. Then, chisel out the hole to make it square (see Fig. 17-7).

STEP

B.10c

FIG. 17-7 - Chiseling a square hole from a round hole

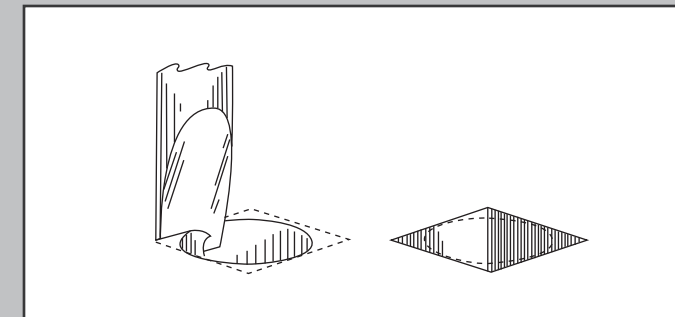

## SECTION B

## SECTION B

STEP

B.10c

FIG. 17-8 - Setting a square baluster in a round hole

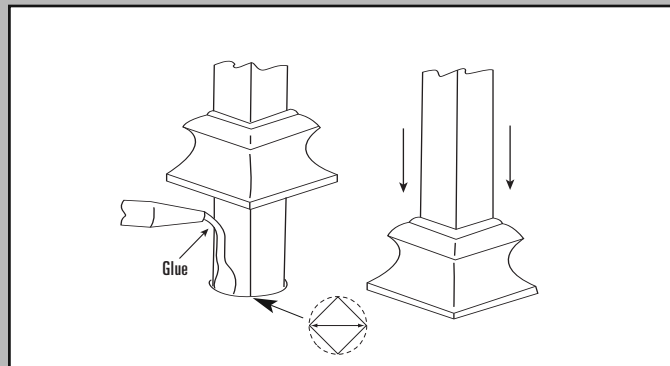

If you use shoes, you may decide to drill a round hole and not chisel it square. This hole will be the size of the diagonal measurement of the baluster and will be hidden by the shoe (some shoes have set screws to hold them in place). We recommend using epoxy in the hole. You may apply the epoxy in one of two ways:

- (1) If you have only a few steps to install, you may put the epoxy in the hole before the baluster. Apply a small amount of epoxy—you don't want it to overflow when the baluster is inserted. Then, put the shoe on the baluster and place the baluster in the hole. Continue up the staircase.

**Important:** the cure time for epoxy is approximately 15 minutes, so you must proceed with speed once you've started!

- (2) If you have several steps to install—or if you don't feel comfortable with scenario #1—then place the baluster in the hole **before** applying the epoxy. Put the epoxy in the hole between the baluster and the side of the hole (see Fig. 17-8). Do not get epoxy on any wood surfaces that you are going to finish.

STEP

B.10c

FIG. 17-9 - Angle shoe usage

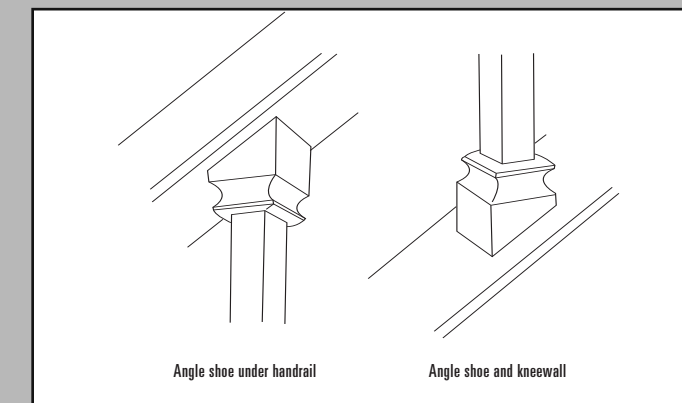

If you are using round forged iron balusters, you may drill a small hole through the baluster and insert a small finishing nail into the wood. Or, you may fit the baluster into a hole of the same size drilled into the tread and allow it to turn.

Angle shoes are used beneath the handrail and where the baluster connects to the treads, and also on installations where a kneewall is used (see Fig. 17-9). A set screw on the side of the shoe will hold it in place.

Forged iron newels are installed differently depending upon their locations:

**Starting step:** Cut a square hole into the tread and riser plates. The hole must be a good, tight fit around the newel. A mortising bit is very helpful for cutting this square hole.

**Intermediate landing:** Drill two holes in the side of the newel and attach the newel to the riser. This is the easiest and strongest method (see Fig 17-10).

**Balcony:** Cut square holes into the floor. Then, depending on under-floor access, either screw the newel into a joist (similar to the way an intermediate newel is screwed into a riser) or attach the newel to the front of the balcony with screws.

FIG. 17-10 - Mounting forged iron newels on intermediate landings

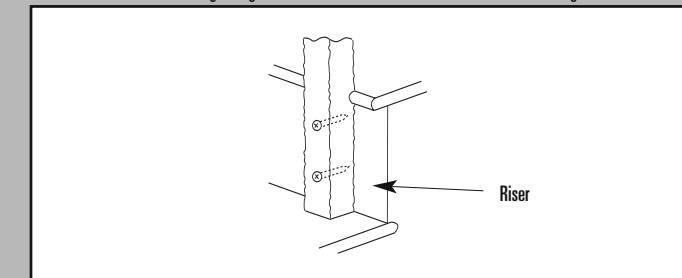

## SECTION B

## SECTION B

STEP  
B.11

## STEP B.11 - Complete the Balustrade Assembly

At this point, all of the components of the balustrade system have been trimmed and fitted, and are ready for final assembly. Treads and newels have been permanently mounted, and the handrail and balusters have been dry fitted. The next (and final) step in the process is applying finishing materials. You may wish to integrate Step B.11 and Step B.12 since some pre-finishing operations are easier to complete before the final assembly is complete.

## B.11a - Stairways with Pin Top Balusters

Working with one flight at a time, glue all of the balusters into their correct positions in the tread.

Apply construction adhesive in each hole you have drilled in the handrail. Working with another person, set the rail onto the baluster tops. Start at the bottom and ease the tops into their holes one at a time.

Press the rail in place and complete the permanent installation. Be sure to align the bottom squares of the balusters with the risers and the finished wall, or skirt board, before the glue begins to set. To maintain this alignment, a small finishing nail may be used through the underside of the rail into the top of the baluster (see Fig. 18-1).

STEP  
B.11a

FIG. 18-1 - Maintaining alignment on pin top balusters

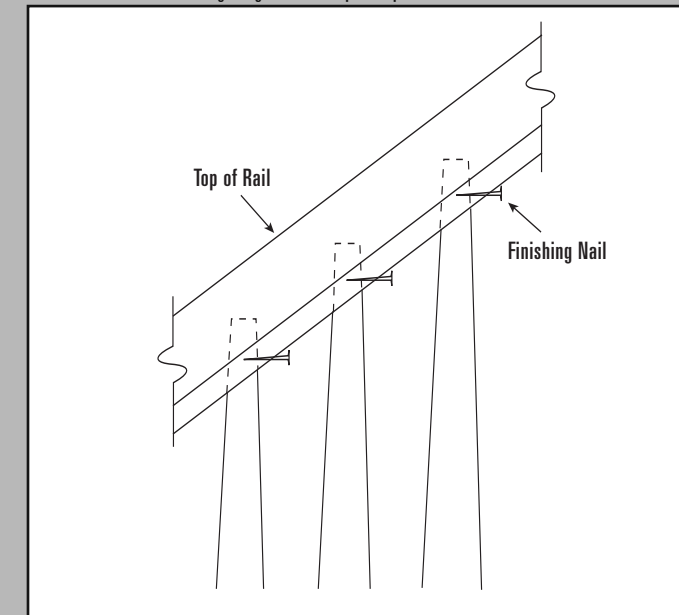

## STAIRNOTE

## ELEVEN

## THE CLASSIC

## COLLECTION:

## BREAKING ALL THE RULES

The Crown Heritage Classic Collection is the easiest to install of all balustrades. It is easy to understand, easy to buy (simplified parts list) and offers several options as to attachment of rails and balusters.

The understated Classic Collection is at home in contemporary residences as well as those with period designs. Inspired by Shaker styling, Classic produces a crisp look that makes a bold statement in several architectural settings.

Begin planning your Classic balustrade by familiarizing yourself with the catalog illustrations of the available components. The lighter 1<sup>1</sup>/<sub>4</sub>" balusters and 3<sup>1</sup>/<sub>2</sub>" newels will yield an airier, more delicate look. Likewise, the 1<sup>3</sup>/<sub>4</sub>" balusters in combination with 4" newels produce a heavier, more solid design. It is also perfectly acceptable to match 1<sup>1</sup>/<sub>4</sub>" balusters to 4" newels or 1<sup>3</sup>/<sub>4</sub>" balusters to 3<sup>1</sup>/<sub>2</sub>" newels. Either combination of components will yield a balustrade that has excellent structural stability.

The handrail also comes in two styles 2<sup>13</sup>/<sub>16</sub>" high or 5<sup>1</sup>/<sub>2</sub>" high. (The 2<sup>13</sup>/<sub>16</sub>" style is most often used as "shoe rail"; mounted parallel to the handrail, but close to the stair treads.)

Careful measurement, notching and anchoring of newels is the key to building a sturdy Classic balustrade. Follow the same principles as with other Crown Heritage newels. Remember, Classic is for "post-to-post" installations, and the newels should project above the handrail.

Once newels are installed, the handrail and/or shoe rail may be clamped into position and marked for final cut. The rails may be installed between posts in true post-to-post fashion or face-applied (see Fig. S-11). Use Crown Heritage Rail Hardware #3 or #4, or wood screws and adhesive to achieve maximum durability.

Balusters should be installed last (dry fitting Classic balustrades is not as important as with more complex balustrades). The most popular method of installing these balusters is to side mount them to the handrail and shoerail.

FIG. S-11 - Face-applied installation of Classic balustrade

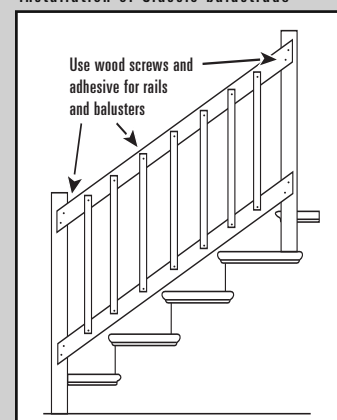

## SECTION B

## SECTION B

STEP

B.11b

FIG. 18-2 - Installing square top balusters

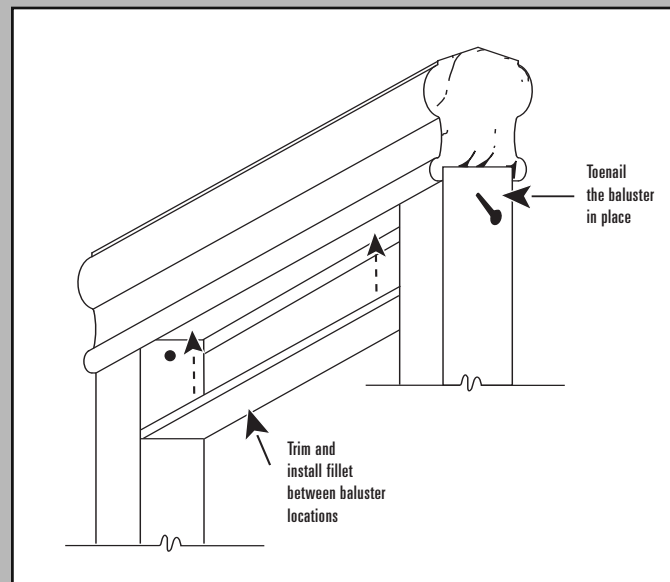

## B.11b - Stairways with Square Top Balusters

Begin by permanently installing the handrail. Use carpenter's glue on all joints, carefully wiping away any excess to avoid finishing difficulties. Sand away smudges and pencil marks and complete light finish sanding in areas that will become hard to reach after assembly. Snug up all bolts and countersink finishing nails. Glue in all wooden plugs and putty the nail heads.

Now you are ready to install the balusters. Start at the bottom of the stairway. Apply glue to both ends and put the dowel into the hole in the tread. Swing it up into the plow on the rail. Align the upstairs face of the square with the plumb mark you made in Step B.10. Drill and toenail the baluster in place with 4d finishing nails (see Fig. 18-2). Do not wedge it under the rail or you will create a bow in the rail, causing the next baluster to fall short.

To avoid bowing the rail and as an aid for toenailing, you may find it helpful to begin at the bottom of the stairway and alternately install fillet then baluster, fillet then baluster, and so forth, working your way to the top of the flight. Use glue and finish nails on the fillet. All fillet sections between balusters should be the same length. Likewise, all fillet sections between balusters and newels should be the same (but somewhat shorter) length because of the extra thickness of the top square of the newel.

Check each baluster to be sure it is plumb as you progress. Sight along the rail to be sure it is straight.

STEP

B.12

STEP B.12 - Stains, Varnishes and Paints:  
Finishing Your Balustrade

All wood parts are subject to dimensional changes that result from loss or absorption of moisture in changing atmospheric conditions. Varnishes and paints reduce the internal stresses caused by moisture changes, and thus all finishes should be applied as soon as possible after wood parts are delivered to the jobsite.

Before finishing, sand all parts with 150 or 180 grit sandpaper. Wipe away all dust. **REMEMBER:** Wood finishes interfere with the ability of glues to bond wood-to-wood, and glues make even penetration of stains impossible.

Save scraps of wood parts to use for testing stains. Stain manufacturers can supply complete details on obtaining the effect you desire. Make sure all smudges, oily finger marks and pencil marks are sanded away before you apply the stain.

Enamel paints and polyurethane varnishes should be applied in multiple coats: two coats for paint, and three for varnish. Between coats, buff lightly with 0000 grade steel wool and wipe away dust with a tack cloth.

Finish all surfaces of the balustrade that are not to be glued. This will maximize the stability of the wood. Occasional waxing of varnished areas with high quality furniture wax will enhance the beauty and durability of the balustrade.

It is now time to enjoy your handiwork and the beauty and value you have added to your home.

## APPENDIX 1

## APPENDIX 1

BENDING RAIL  
INSTALLATION

FIG. A1-1 - Bending rail guides

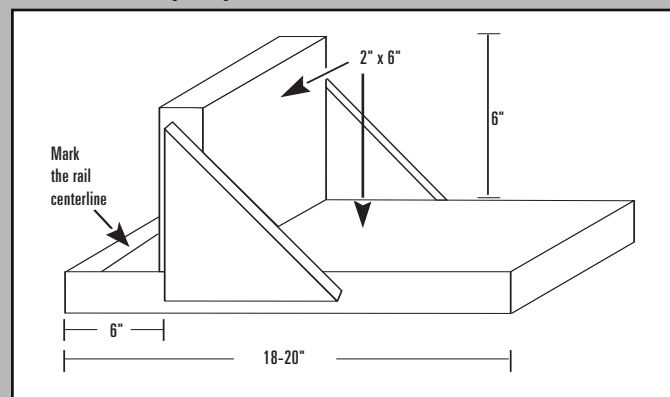
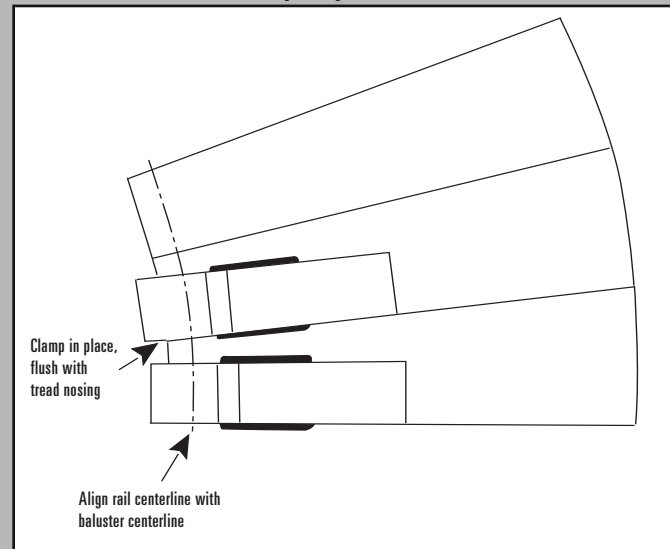

FIG. A1-2 - Placement of bending rail guides



Read all instructions carefully before starting.

The following procedures provide guidance for assembling curved balustrades and balcony handrails.

**STEP 1: Important Considerations Prior to Starting**

The run, rise and radius of the staircase where the curved rail is to be installed must be constant. For successful results, the radius of the stairway should not be less than the following:

**STAIRCASES**

6010B (30")    6210B (30")    6519B (36" to 42")

**LEVEL BALCONY HANDRAIL**

6010B (36")    6210B (42")    6519B (36" to 42")

**STEP 2: Bending Guides**

Build the bending guides as in Fig. A1-1. You will need a bending guide for each tread. Find the centerline of the rail by measuring the total width of the rail, including the bending mold, and dividing this width in half. Mark the centerline on each bending guide, measuring from the vertical brace. To protect the treads from glue, cover them with a clear plastic.

Now, clamp the guides to the treads, keeping the rail centerline aligned with the baluster centerline. The leading edge of the bending guide must be flush with the tread nosing. Fig. A1-2 shows proper placement of the bending guides.

The same basic procedure is used for a curved balcony.

**STEP 3: Constructing the Bending Rail**

The inside of the bending mold should be covered with wax paper or plastic to prevent the glue from sticking to the mold.

Special care must be taken if the required rail length is longer than 16'. Shorter rails have to be spliced together to provide these lengths. A butt joint on each layer of rail is used to make this splice. These butt joints must be staggered about 30" to maintain strength throughout the splice and to minimize the bulge in the rail. Each butt joint should have a 10" strip of nylon tape to hold the pieces together while bending the rail (see Fig. A1-3).

Apply a thin even coat of carpenter's glue to all contact surfaces of the rail; a finishing sponge or tape roller would be helpful. The rail should be assembled one layer at a time, gluing each piece completely, starting from one bending mold section and finishing with the other bending mold section. Once assembled, use nylon tape to wrap the rail about every 3'. This provides support while the rail is being bent.

Clamp the rail at one end. Form the rail to the curve by carefully pulling the rail to the guides and clamping it. At each bending guide, clamp the rail to the vertical brace, keeping the rail down on the front edge of the guide. Continue one guide at a time to the end of the rail. A clamp should be placed on each guide and between the guides, no more than 6" apart (see Fig. A1-4). Clamp the rail as often as possible to provide a smooth bend in the rail and good glue adhesion.

BENDING RAIL  
INSTALLATION

FIG. A1-3 - Splicing bending rail

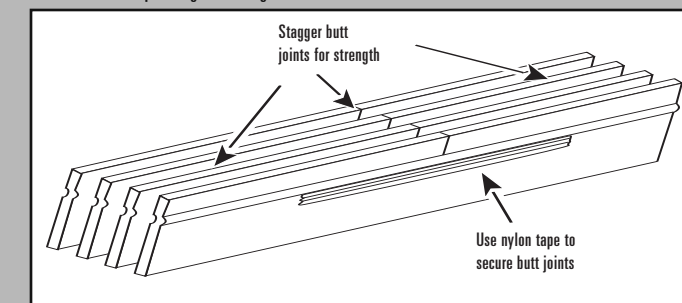
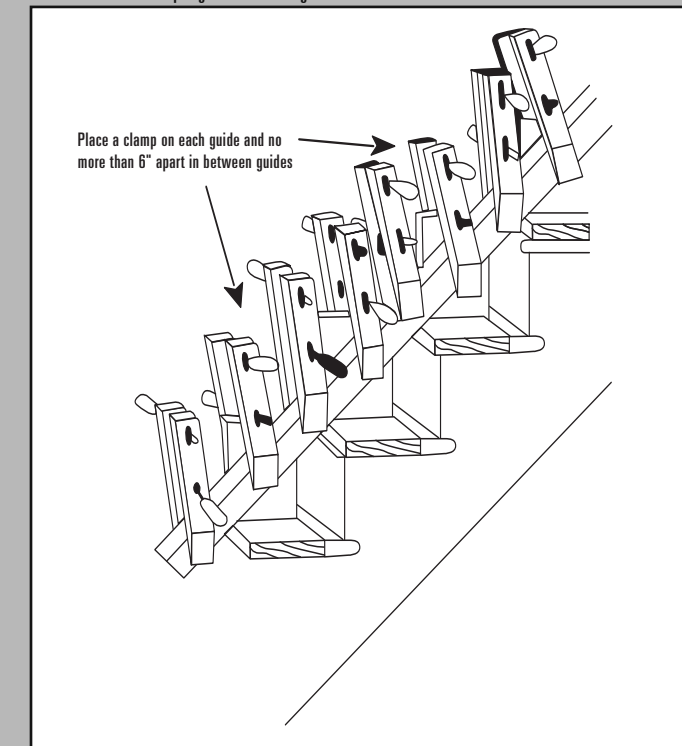

FIG. A1-4 - Clamping the bending rail



## APPENDIX 1

## APPENDIX 2

BENDING RAIL  
INSTALLATION

Normally bending rails may be removed from the bending guides in 24 to 48 hours. Extra drying time is recommended when the rail is bent to a tight radius. Unclamp the rail and remove the bending guides. Separate the rail from the bending mold. The excess glue can be removed with a hand belt sander or an electric hand planer.

**STEP 4: Finishing the Bending Rail Balustrade**

Install newels, fittings and balusters according to normal instructions. It is best to install and finish the bending rail immediately.

**PROBLEM:**

A standard up easing will not work with the necessary newel locations.

**SOLUTION:**

Use of a 90° up easing may enable an effective transition to the handrail rake. The starting step may require an increased run (see Fig. A2-1).

**PROBLEM:**

Rail drop is greater than available with a 2-rise gooseneck.

**SOLUTION:**

An additional length of handrail can be added to the gooseneck to increase rail drop (see Fig. A2-2).

TROUBLESHOOTING  
REFERENCE

FIG. A2-1 - Use of 90° up easing with unique newel location

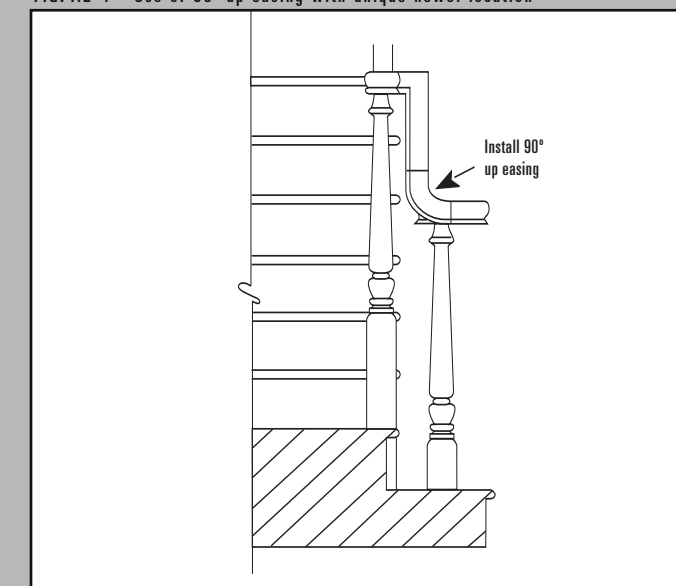
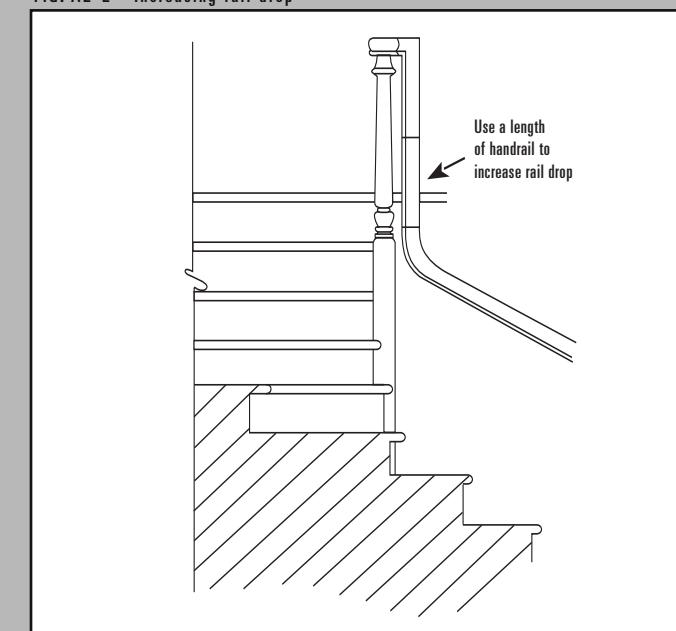

FIG. A2-2 - Increasing rail drop



## APPENDIX 2

## APPENDIX 2

TROUBLESHOOTING  
REFERENCE

FIG. A2-3 - Use of an overeasing at the balcony

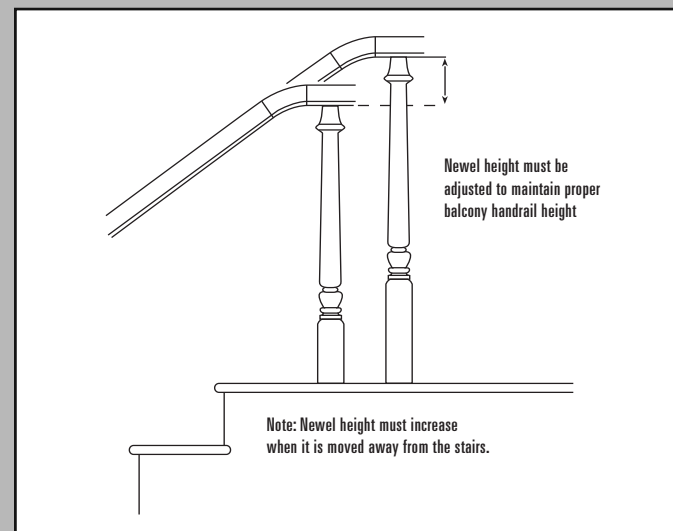
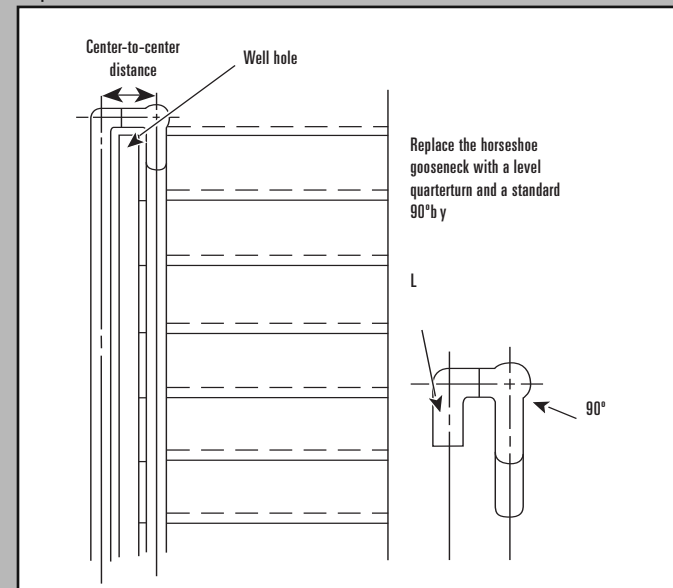

FIG. A2-4 - Alternate method to achieve required well hole center-to-center distance

**PROBLEM:**

Instead of a standard gooseneck, an overeasing is desired at the balcony.

**SOLUTION:**

The landing/balcony newel height must be adjusted to maintain the proper balcony handrail height. Note: Newel height must increase the further from the stair the newel is placed (see Fig. A2-3).

**PROBLEM:**

The horseshoe gooseneck fitting does not fit the well hole center-to-center distance.

**SOLUTION:**

By adding a level quarter-turn to a standard 90° balcony gooseneck, the center-to-center distance can be achieved (see Fig. A2-4).

**PROBLEM:**

A section of level rail is needed on an intermediate landing.

**SOLUTION:**

(See Fig. A2-5) Newels "A" and "B" should be the same height. The balusters on the landing may need to be longer, and a 2-rise gooseneck may be required. Newel "B" should use a starting easing.

TROUBLESHOOTING  
REFERENCE

FIG. A2-5 - Use of level rail on a landing

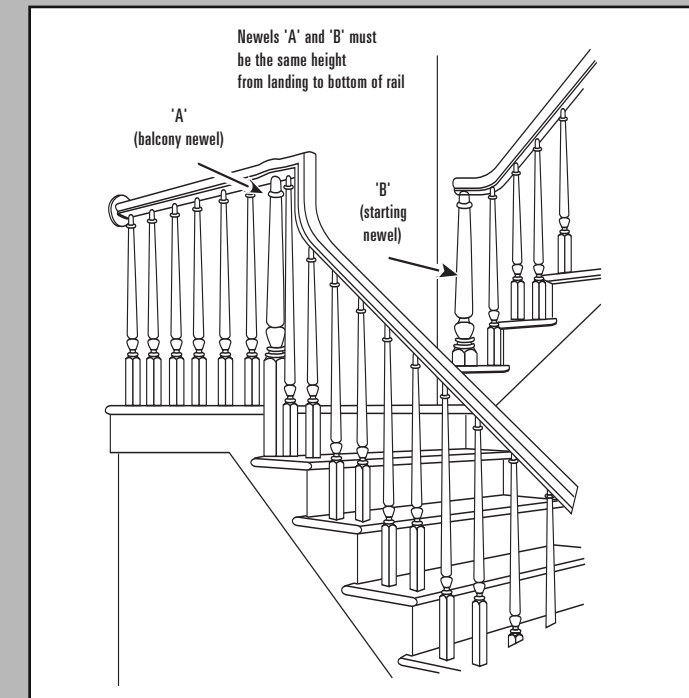
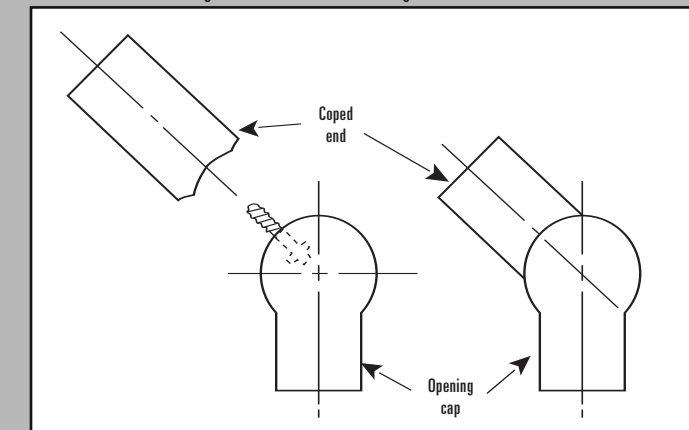

FIG. A2-6 - Achieving different level turn angle

**PROBLEM:**

The level turn angle is different than the quarterturn cap angle.

**SOLUTION:**

Use an opening cap with a coped end attached using a rail bolt to achieve the desired angle (see Fig. A2-6). If the level turn angle is 45°, use a 7021A or 7221A.

## APPENDIX 3

## APPENDIX 3

## HARDWARE INSTALLATION INSTRUCTIONS

FIG. A3-1 - Drilling holes in the rail

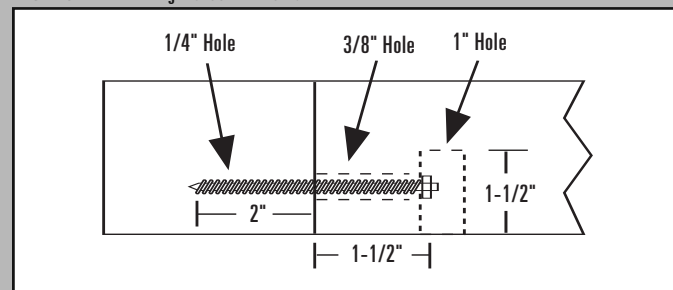

FIG. A3-2 - Attach the rail to the post

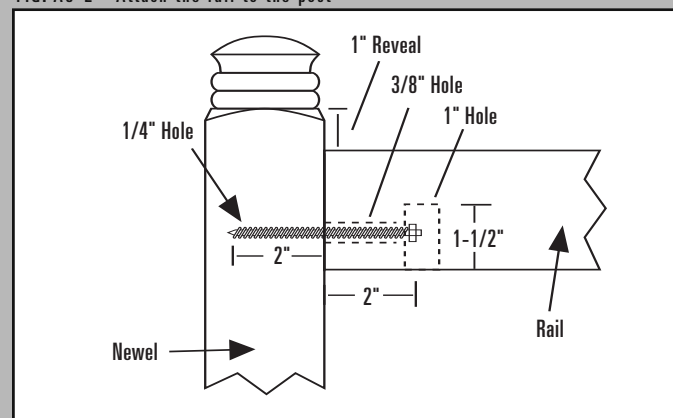
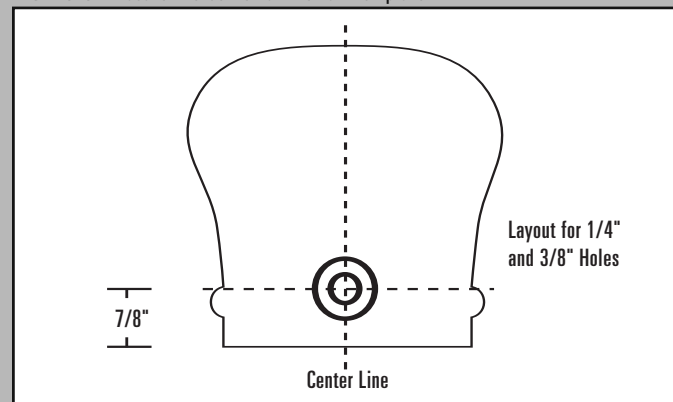

FIG. A3-3 - Locate the center of the rail template



### 3001 Rail Bolt Installation Instructions

#### Tools Needed:

- Reversible Drill
- Box end wrench - 1/2"
- Drill bits - 1/4", 3/8" & 1"
- Hammer

1. Saw a small 1/4" thick piece off the end of the rail that will serve as a template. Drill a small hole in the template to center the bolt holes (see Fig. A3-3).
2. Cut the rail to the desired length.
3. If you are installing rail to a newel then trace the outline of the rail template onto the newel face to help locate the correct position of the newel for the rail.
4. If you are connecting rail to a fitting then the wood screw should be installed into the fitting.
5. Drill a 1" hole 1 1/2" deep in to the rail taking care not to penetrate the top of the rail with the bit (see Fig. A3-1).
6. Drill a 3/8" hole into the rail (see Fig. A3-1). Use the template and see Fig. A3-3 to help position.
7. Install the screw (this will be the wood screw end of the bolt) into the fitting or newel face.
8. If this installation is into a newel face then it will work only at one end of the rail and newel intersection and not both ends (see Fig. A3-3).
9. Apply a small amount of wood glue to the face of the rail.
10. Position the rail with a machine screw in the 3/8" hole, affix the washer and nut and tighten using a box end wrench (see Fig. A3-2). Apply wood glue to the plug (choose an oak or poplar plug) and install into the 1" hole in the bottom of the rail. After the glue is dry, sand, flush and stain.

### 3076 Baluster Fasteners Installation Instructions

#### Tools Needed:

- Drill bit - 1/4"
- Reversible Drill

#### Optional tool:

- #3088 Dowel Driver - very helpful

*NOTE: If you are using #3076 Dowel Screw with pre-drilled balusters, skip to Step 4.*

1. Cut the baluster to the needed length. The bottom of the baluster must be cut square.
2. Mark the center of the bottom of the baluster by drawing a line from each corner across the middle (see Fig. A3-4).
3. Drill a 1/4" hole into the bottom of the baluster 1" deep. Also drill a 1/4" hole into the floor or tread.
4. Drive dowel screws into the bottom of the balusters using a drill (with the optional #3088 Dowel Driver) into the hole in the tread or the floor and twist the baluster.

#### Optional Method:

Drive dowel screws into the tread or floor and then twist the baluster onto the dowel screw.

## HARDWARE INSTALLATION INSTRUCTIONS

FIG. A3-4 - Mark the center of the bottom of the baluster

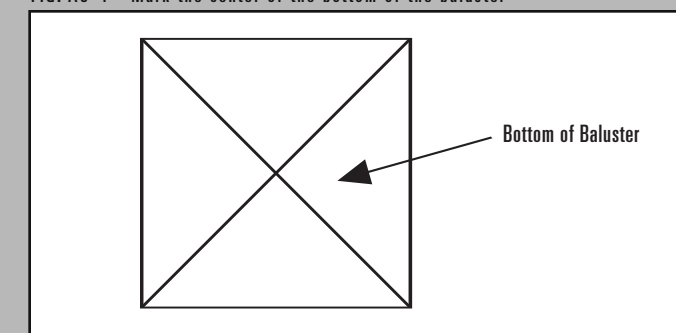

## APPENDIX 3

## APPENDIX 4

HARDWARE INSTALLATION  
INSTRUCTIONS

FIG. A3-5 - Connecting a handrail to a newel post

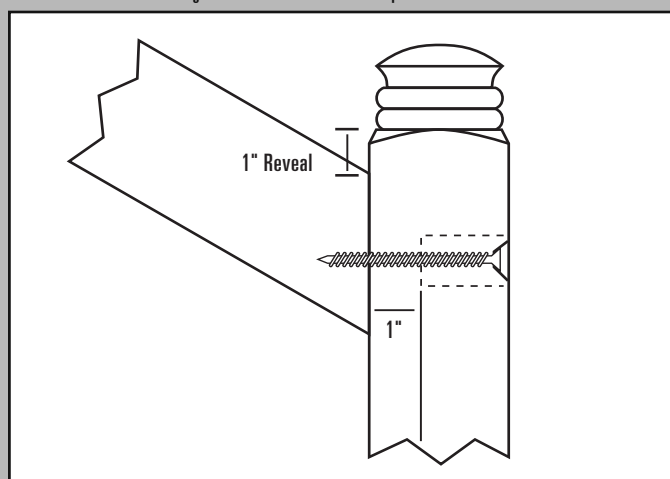
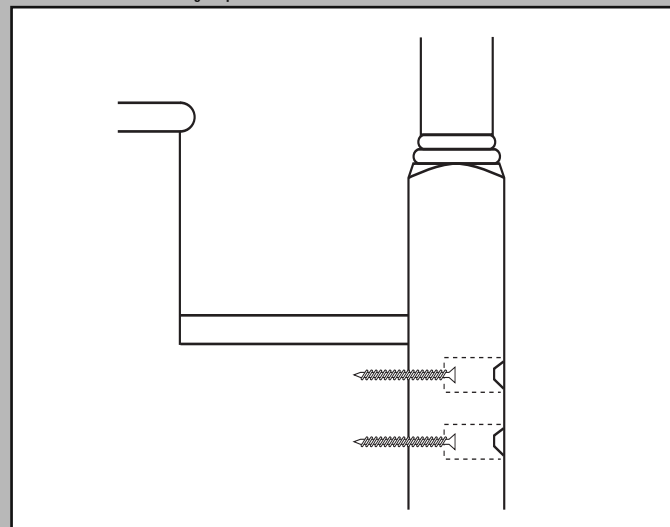

FIG. A3-6 - Connecting a post to a riser



## 3078 Rail &amp; Post Fastener Installation

## Tools Needed:

- Socket wrench
- Drill bits - 1/4", 7/16" & 1"
- Reversible Drill

## Connecting Handrail to Newel Post (see Fig. A3-5)

1. Trim the handrail to the needed length. Mark the center end of the handrail for a 1/4" pilot hole. Allow for the correct angle of the rail and for a 1" reveal on the newel face above the rail.
2. Drill a 1" hole toward the rail into the front face of the newel. This hole should be 2" deep for a 3" newel and 2 1/2" deep for a 3 1/2" newel.
3. Drill a 7/16" hole (inside the hole drilled in step 2) through the newel. Then drill a 1/4" pilot hole 2" deep into the end of the rail. **The hole through the newel and the hole in the rail must line up.**
4. Tighten the bolt with a socket wrench. Apply wood glue to the inside of the 1" hole and tap the wood plug into the hole until it is almost flush with the face of the newel. Let it dry, then sand flush and finish.

## Connecting Post to Riser - Requires two #3078 Rail and Post Fasteners (see Fig. A3-6)

1. Notch and trim the newel post as needed.
2. Drill two 1" holes into the newel until the bottom of the hole is 1" from the inside newel face.
3. Drill a 7/16" hole (inside the 1" hole) the rest of the way through the newel. Then drill a 1/4" hole into the riser to receive the wood screw part of the bolt.
4. Tighten the bolt with a socket wrench. Apply wood glue to the inside of the 1" hole and tap a wood plug into the hole until it is almost flush with the face of the newel. Let it dry, then sand flush and finish.

The Promenade Series by Crown Heritage is a stair system designed for exterior use. It is ideal for porches, decks and captain's walks.

The styling of the Promenade Series is developed from the architecture of ancient Greece. The series contains its own distinct newels, handrail, shoerail and balusters. The balusters are available in two styles: Classical and Chateau. The combination of Old World style and traditional craftsmanship offers an original balustrade with historical charm and strength.

The Promenade components, shown in Fig. A5-1, are designed to provide a clean appearance and ease of installation. The newels are shipped in three parts: the cap, base and box. A two-part handrail design is used to minimize unsightly exposed screw holes. The shoerail is used to provide support for the balusters.

Various sizes are offered in the Promenade Series, and the newels, balusters, handrail and shoerail must be matched according to size. Review the guidelines presented in the catalog before ordering.

Although there is some flexibility, the Promenade Series balustrade should be laid out to maximize space on the deck or walkway, while maintaining alignment consistent with other stairway systems. Newels must be installed only at locations with structural framing support. Careful measurement and anchoring of newels and balusters will provide safety and strength.

THE PROMENADE  
SERIES

FIG. A5-1 - Easy-to-use promenade components

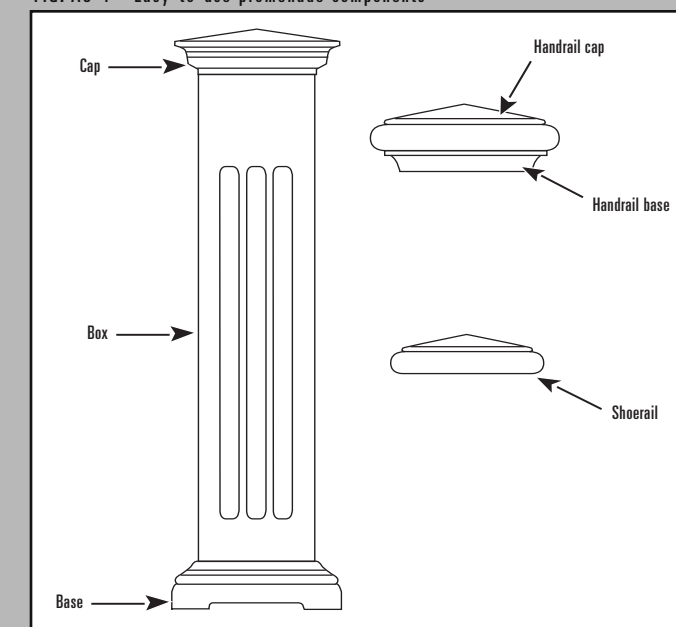

## APPENDIX 4

## APPENDIX 4

THE PROMENADE  
SERIES

FIG. A5-2 - Promenade baluster installation

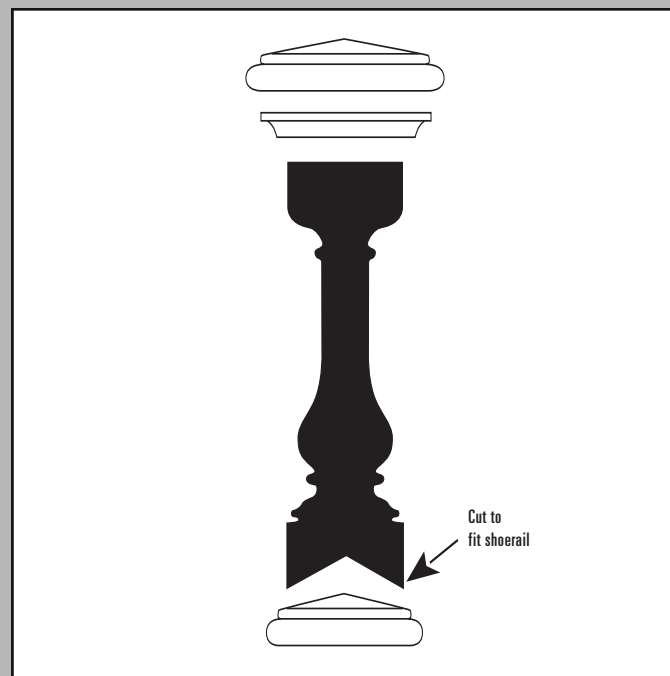

Baluster placement depends on the size of balusters and desired look, with a recommended spacing between centerpoints of 6" to 10". Determine placement for consistent spacing between all centerpoints (balusters and newels). This will help you figure the number of balusters required.

**WARNING:** Although the Promenade Series is designed for exterior use, any wood is subject to weather damage if not properly sealed. To preserve the beauty of your Promenade balustrade, it is critical to adequately seal all ends of the rail, newels and balusters that may be exposed to the elements. Sealing is achieved by using careful measurement, cutting for precise fit and applying a good quality wood sealer. After sanding and applying wood sealer, thoroughly seal the ends with paint. Sealing of all exposed ends during construction and upon completing of the balustrade will not only protect the wood but increase the beauty of the final finish. Failure to properly seal the exposed components will void any claims against defects. of course, all parts must be primed and painted with high-grade exterior paint.

Newels are installed first. Drill a  $\frac{7}{16}$ " hole through the center of the base. Two additional  $\frac{1}{4}$ " holes should be drilled through the base for drainage. Using a  $\frac{3}{8}$ " lag screw with a fender washer, secure the base to a structural framing member. Position the newel box over the neck of the base, and secure to the base using galvanized finish nails or screws. The cap is installed later.

The construction of the Promenade handrail begins with preparation of the balusters. Cut a 1" long section of the shoerail for a template. The balusters will be cut to fit on the shoerail as shown in Fig. A5-2. With the template flush to the bottom of the baluster, trace the outline onto the baluster. Carefully cut out this section of the baluster. Begin with rough cuts, and then trim for best fit.

**WARNING:** It is critical to sand and seal the baluster ends. If not thoroughly sealed, the balusters will wick water and rot.

Mark the shoerail according to the baluster centerpoint spacing determined earlier. Invert the balusters and place inverted shoerail in position aligning balusters with marked centerpoints. At each centerpoint drill two  $\frac{1}{8}$ " holes, offset-from-center, through the shoerail and into the bottom of the baluster, as pilot holes. Now position the shoerail so the holes at each centerpoint can be drilled out to  $\frac{1}{4}$ " without drilling into the balusters.

Fasten the shoerail to the balusters using two 3" x #12 screws offset from center. Once all balusters are attached, stand the assembly upright.

Position the handrail base on top of balusters and align with the shoerail. At the same centerpoint spacing as the shoerail, drill one  $\frac{1}{8}$ " hole at each centerpoint in the handrail base and into the top of the baluster. Remove the handrail base to allow drilling each centerpoint to  $\frac{1}{4}$ " without boring into the balusters. Realign the handrail centerpoints and assemble with 2" x #12 screws.

After balusters are secured to the handrail base, drill two  $\frac{1}{8}$ " holes through the handrail base at a position centered between the balusters and 1" in from each outside edge. Spread a thin layer of exterior wood glue along the top of the handrail base. Be careful to keep the glue  $\frac{1}{4}$ " from the edges to minimize glue leakage when the handrail cap is attached to the base. Position the handrail cap on the base and align evenly. At previously drilled points between the balusters, secure the cap to the base with  $1\frac{1}{2}$ " x #8 screws from the underside of the base. Any glue leakage must be quickly wiped away. Any area where you have wiped away glue should be lightly sanded. The handrail section is now complete and ready to be painted or stained.

THE PROMENADE  
SERIES

## APPENDIX 4

## APPENDIX 5

### THE PROMENADE SERIES

**WARNING:** Prior to painting or finishing the completed balustrade, verify all exposed ends of newels, balusters, and railings are adequately sealed. Complete sealing is necessary to protect the wood from weather damage.

After finishing the handrail section, the assembly can be attached to the newel posts using two lag bolts and washers from inside the newel post box. As an alternative, you may choose to angle screws into the newel post from the underside of the rail. Once the rail is secured, the newel cap is installed and attached to the newel box using galvanized finish nails or screws.

*NOTE: For long sections in the rail assembly, support spacers between the shoerail and the floor are recommended to reduce sagging. The spacers should be placed every two to three feet and at each end of the assembly.*

### SPHERE RULE TABLE

The following chart contains columns which provide maximum tread run information regarding the 4" sphere rule and the newer code rule of 4<sup>3</sup>/<sub>8</sub>" sphere rule (see boldface explanation at the end of Step B.1a). Visit the Crown Heritage Design Library for information on proper spacing requirements, at [www.crownheritage.com](http://www.crownheritage.com).

PRODUCT NO.	BALUSTER DIAMETER	MAXIMUM TREAD RUN FOR COMPLIANCE	
		4" SPHERE RULE	4 <sup>3</sup> / <sub>8</sub> " SPHERE RULE
5010 . . . . .	1 <sup>1</sup> / <sub>4</sub> " . . . . .	9 <sup>1</sup> / <sub>4</sub> " . . . . .	10"
5015 . . . . .	1 <sup>1</sup> / <sub>4</sub> " . . . . .	9 <sup>1</sup> / <sub>4</sub> " . . . . .	10"
5060 . . . . .	1 <sup>1</sup> / <sub>4</sub> " . . . . .	10 <sup>1</sup> / <sub>2</sub> " . . . . .	11 <sup>1</sup> / <sub>4</sub> "
5067 . . . . .	1 <sup>1</sup> / <sub>4</sub> " . . . . .	9 <sup>1</sup> / <sub>2</sub> " . . . . .	10 <sup>1</sup> / <sub>4</sub> "
5141 . . . . .	1 <sup>1</sup> / <sub>4</sub> " . . . . .	9 <sup>1</sup> / <sub>2</sub> " . . . . .	10 <sup>1</sup> / <sub>4</sub> "
1805 . . . . .	1 <sup>3</sup> / <sub>4</sub> " . . . . .	10 <sup>1</sup> / <sub>4</sub> " . . . . .	11"
1815 . . . . .	1 <sup>3</sup> / <sub>4</sub> " . . . . .	9 <sup>1</sup> / <sub>2</sub> " . . . . .	10 <sup>1</sup> / <sub>4</sub> "
2005 . . . . .	1 <sup>3</sup> / <sub>4</sub> " . . . . .	10 <sup>1</sup> / <sub>4</sub> " . . . . .	11"
2015 . . . . .	1 <sup>3</sup> / <sub>4</sub> " . . . . .	9 <sup>1</sup> / <sub>2</sub> " . . . . .	10 <sup>1</sup> / <sub>4</sub> "
5005 . . . . .	1 <sup>3</sup> / <sub>4</sub> " . . . . .	10 <sup>1</sup> / <sub>4</sub> " . . . . .	11"
5105 . . . . .	1 <sup>3</sup> / <sub>4</sub> " . . . . .	10" . . . . .	10 <sup>1</sup> / <sub>4</sub> "
5300 . . . . .	1 <sup>3</sup> / <sub>4</sub> " . . . . .	9 <sup>1</sup> / <sub>2</sub> " . . . . .	10 <sup>1</sup> / <sub>4</sub> "
5360 . . . . .	1 <sup>3</sup> / <sub>4</sub> " . . . . .	11 <sup>1</sup> / <sub>2</sub> " . . . . .	12 <sup>1</sup> / <sub>4</sub> "
9005 . . . . .	1 <sup>3</sup> / <sub>4</sub> " . . . . .	10 <sup>1</sup> / <sub>4</sub> " . . . . .	11"
9015 . . . . .	1 <sup>3</sup> / <sub>4</sub> " . . . . .	9 <sup>1</sup> / <sub>2</sub> " . . . . .	10 <sup>1</sup> / <sub>4</sub> "

